

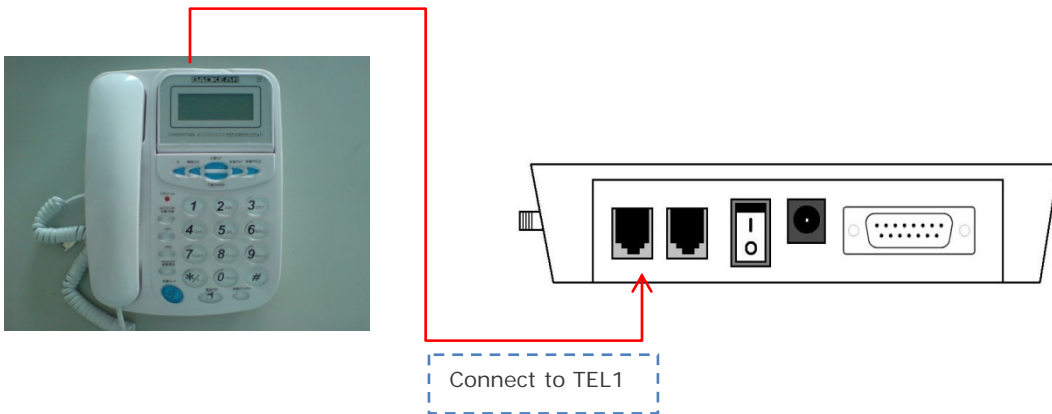

WT-1010C2

GSM ALARM SYSTEM



How to connect to alarm Panel ?

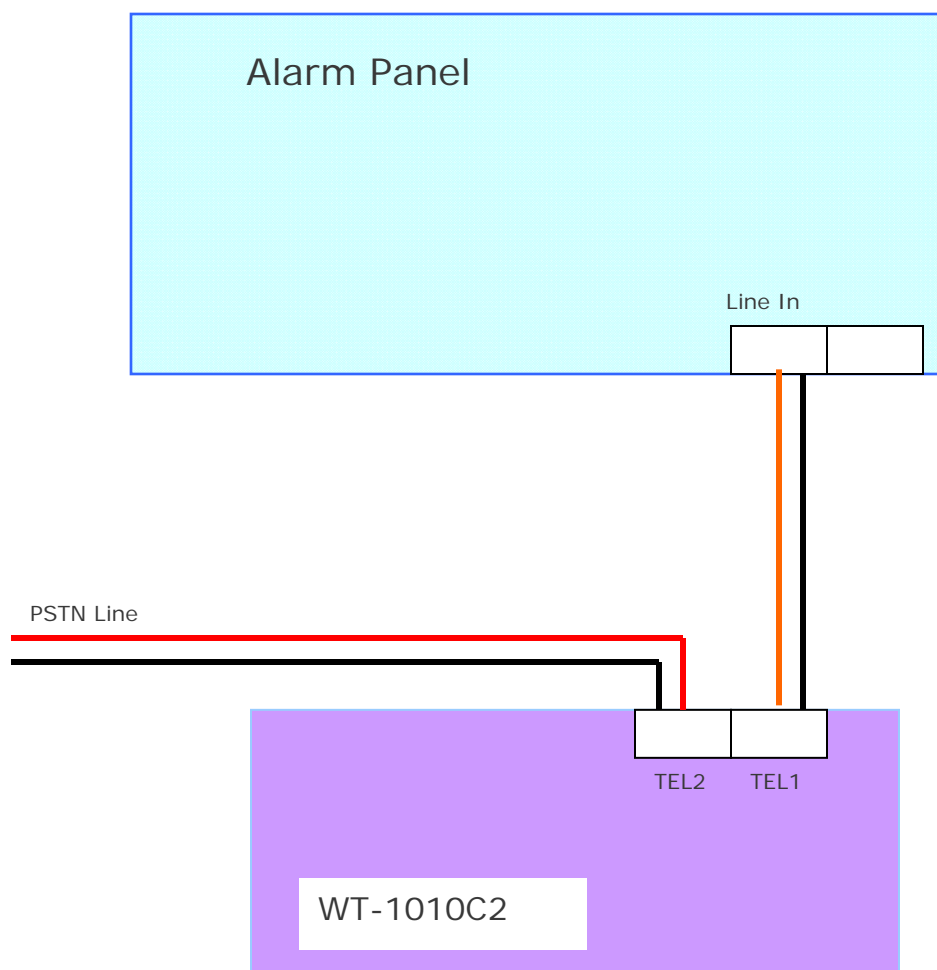

Programming

1) Enter Programming Mode

Pick up the handset or press hands free, press ****123456#** to enter programming mode. If the password has entered correctly, you should see "HAND FREE..." displayed on WT-1010C2 screen.

2) Reset the Main Unit

To reset the unit, you can press ***15***

Then press **1#** to reset.

3) Programming the Administrator/Central Station Number

Press ***1*** then programming the administrator number and

Ended with #

Example: ***1*12334567#** (1st number)

***2*22233344#** (2nd number)

You may continue to program administrator number 2, 3, 4, 5, 6, 7 and 8 by

Pressing ***2*** , ***3*** , ***4*** , ***5*** , ***6*** , ***7*** or ***8***

4) Setting for Calling a group of administrator numbers

To program the unit to dial a certain group of numbers when PSTN/AC failed or Auto Test, you can press ***29*** to proceed.

For example: If program **2** Administrator number so the calling group will set as

***29*2#**.

If **3** Administrator so the calling group will set as ***29*3#**.

5) Programming the Area Code

To program area code, you can press ***9*** to proceed.

For example: ***9*03#**(03 is the Kuala Lumpur Area code)

6) Setting the Function of Adding Area Code when Transmitting an Alarm

To turn on/off this function, you can press ***14*** to proceed.

To turn on the Area code function simply press **1#**

To turn off the Area code function simply press **0#**

7) **"PSTN Failure" Setting**

To do this setting, you can press ***30*** to proceed.

Setting the unit to generate an Alert Message, call the administrators, generate a pulse (+V) and sound the audible alarm when PSTN failed. Press **00011#**

PST: ME: 0 OU: 0 AL: 0
CA1: 1 CA2: 1 OK

Note: *"ME"* stands for generation of SMS when PSTN failed

"OU" stands for generation of pulse (+V) when PSTN failed

"AL" stands for sounding the audible alarm when PSTN failed

"CA1" stands for calling the administrators when PSTN failed

"CA2" stands for calling the administrators when PSTN connected

Value: ON (1) or OFF (0)

8) **Setting the Account Number for Event Reporting**

When PSTN failure, AC failure or Auto Test, the WT-1010C2 will dial the programmable central station number and transmit the account number along with Contact-ID to the central station. To set the account number, you can press ***36*** to proceed

Example: To set the account number as 9999, then press ***36*9999#**

Note: *The account number must entered in 4 digits*

Additional Function Programming

"AC Failure" Setting

To do this setting, you can press ***31*** to proceed

Example: Setting the unit to generate an Alert Message, call the administrators, generate a pulse (+V) and sound the audible alarm when PSTN failed.

Press **0011#**

ADC: ME: 0 AL: 0 CA1: 1
CA2: 1 OK

Note: *"ME"* stands for generation of SMS when AC failed

"AL" stands for sounding the audible alarm when AC failed

"CA1" stands for calling the administrators when AC failed

"CA2" stands for calling the administrators when AC connected

Value: ON (1) or OFF (0)

Time Setting

To setup display time, you can press ***16*** to proceed.

TIME: 08 : 30 : 00

Example: To set the time at 8.30am
Simply input digits and ended with #



TIME: 08 : 30 : 00
OK

Auto Test Setting

1) Setting the Auto Test Report Time Interval

The system has the function of sending the test report to the central station at the programmable time interval. The time is entered in 24 Hour format.

To set the auto test report time interval, you can press ***17*** to proceed.

DSTM: 12 : 00 : 00

Example: To set the auto test report time at 12.00pm

Simply input digits and ended with #



DSTM: 12 : 00 : 00
OK

2) Setting the Auto Test Report Time Section 2

The system has the function of sending the test report to the central station at the programmable time section. The time is entered in 24 Hour format.

To program the auto test report time section 2, you can press ***42*** to proceed.

DSTM2:
18 : 00 : 00

Example: To set the auto test report time at 18.00pm

Simply input digits and ended with #



DSTM2:
18 : 00 : 00 OK

3) Setting the Auto Test Report Time Section 3

The system has the function of sending the test report to the central station at the programmable time section. The time is entered in 24 Hour format.

To program the auto test report time section 3, you can press ***43*** to proceed.

DSTM3: 23 : 59 : 00

Example: To set the auto test report time at 23.59 pm

Simply input digits and ended with #



DSTM3: 23 : 59 : 00 OK

4) Enable/Disable the function of dialing the programmed Administrator number for Auto Test

To turn on this function, you can press ***27*** to proceed.

To turn on Auto Test function simply press **1#**

To turn off Auto Test function simply press **0#**