

8-ZONE ALARM CONTROL PANEL
WITH COMMUNICATOR AND AUTO-DIALER

HA-982

OPERATOR'S MANUAL



SINCE 1979



TABLE OF CONTENTS

INTRODUCTION	3
THE SYSTEM CONTROL CONSOLE AND ITS INDICATORS	4
The Sound Indicators	4
The LED Light Indicators	5
ARMING THE SYSTEM	6
To Arm The System	6
To Arm The System Instantly	6
To Arm The System In HOME Mode	7
To Arm The System Instantly In HOME Mode	7
To Arm The System With Manually Isolated Zone(s)	8
ARMING OPTION	9
TRIGGERING OPTION	10
DISARMING THE SYSTEM AND TO CLEAR THE ALARM MEMORY	11
To Disarm The System	11
To Disarm The System After An Alarm Occurs	11
To Clear The Alarm Memory	12
To Clear The Alarm Memory And Re-arm The System In One Time	12
24-HOUR MONITORING AND ALARM REPORTING	13
EMERGENCY CASES	14
To Make A Panic Alarm	14
To Make A Duress Alarm	14
TESTING YOUR SYSTEM	15
Standby Battery Testing Routines	15
Standby Battery Test--Periodic	15
Standby Battery Test--Manual	16
Testing The Local Alarm Outputs	16
Testing The Telephone Numbers In Communicator And Auto-dialer	17
CHANGING AND DELETING	18
Recording The Alarm Reporting Message For Auto-dialer	18
Changing A Master Code	19
Changing A User Code	19
Deleting A User Code	20
Changing A Telephone Number In Auto-dialer	20
Deleting A Telephone Number In Auto-dialer	21
ALARM REPORTING AND ACKNOWLEDGEMENT	22
Receiving An Alarm Reporting Message And Giving Acknowledgement	22
Initiating The Listen-in Function	23
REMOTE ACCESS THE SYSTEM BY TELEPHONE	24

Checking The Arm-disarm Current Status	24
Remote Arm-disarm The System.....	24
The command Codes For Remote Access Control--Summary	26
Requesting A current Status Report	27
ARMING-DISARMING CONTROLS BY KEY SWITCH--OPTIONAL	28
Utilize The Remote Key Switch For System Arm-disarm Controls	28
The LED Light Indicators For Remote Key Switch.....	28

INTRODUCTION

Thank you for choosing the HA-982 alarm control system to protect you and your property. Your system is one of the most powerful and advanced alarm systems on the market today, designed to provide you with years of reliable service.

This operation manual is one of the two manuals for the HA-982 alarm control panel, which explains how to operate your alarm system. To get most from the alarm system, we suggest that you take time to read through the manual to get acquainted with its many features and all the operating procedures.

The installation instructions of the alarm system are described in the **Installation Manual**.

THE SYSTEM CONTROL CONSOLE AND ITS INDICATORS

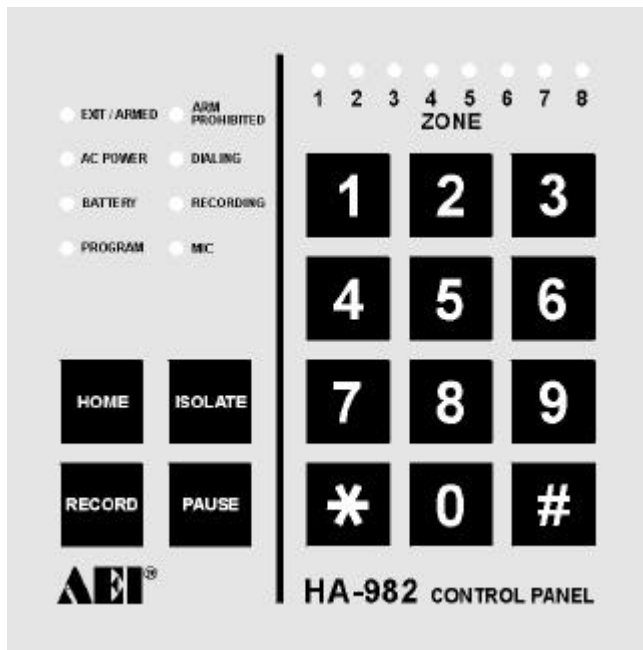

HA-982S

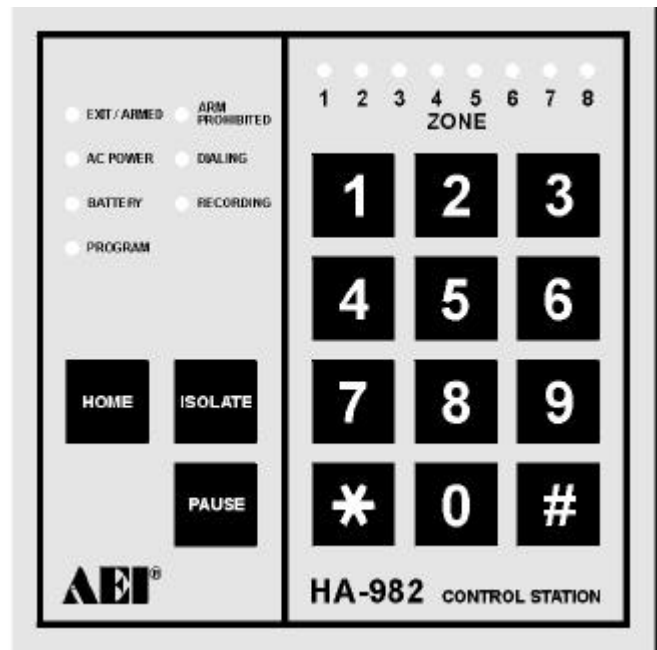

HA-982R

THE SOUND INDICATORS

SOUND	MEANING
1 short beep	<ul style="list-style-type: none"> ● Successful key entry, a pacifier tone
2 short beeps	<ul style="list-style-type: none"> ● Successful code entry for the specific function
5 short beeps	<ul style="list-style-type: none"> ● Unsuccessful code entry for the specific function ● Wrong code number entered ● Unauthorized command attempted ● Code entry time expired, 10 seconds maximum per digit is allowed
1 long beep	<ul style="list-style-type: none"> ● Exit delay expired, system is armed
1 short beep/30 seconds	<ul style="list-style-type: none"> ● AC power failure ● Battery low
Continuous beeping at 0.5 second interval	<ul style="list-style-type: none"> ● Exit delay time ● Entry delay time ● The DAP jumper is ON
Continuous 5 short beeps/5 seconds interval	<ul style="list-style-type: none"> ● The telephone line is faulty after line fault testing
2 beeps + 5 beeps	<ul style="list-style-type: none"> ● System can not be armed instantly due to ARM PROHIBITED ● Duress code is entered but the communicator is not working

THE LED LIGHT INDICATORS

INDICATORS	ON	OFF	FLASHING
ZONES (8 LEDs)	<ul style="list-style-type: none"> ● Zone unsealed (<i>faulted</i>) Please check the zone connections 	<ul style="list-style-type: none"> ● Zone sealed (<i>Normal</i>) 	<p>FLASHING FAST</p> <ul style="list-style-type: none"> ● Zone is or was in alarm <p>FLASHING FAST WITH STOPPING INTERVAL</p> <ul style="list-style-type: none"> ● Zone is in alarm memory, system is disarmed <p>FLASHING SLOW</p> <ul style="list-style-type: none"> ● Zone is isolated
EXIT/ARMED	<ul style="list-style-type: none"> ● Alarm armed 	<ul style="list-style-type: none"> ● Alarm disarmed 	<ul style="list-style-type: none"> ● In exit delay period
AC POWER	<ul style="list-style-type: none"> ● AC Power is being supplied 		<ul style="list-style-type: none"> ● AC power failure, system is using battery ● Flashing starts 20-30 seconds after AC power failure <p>FLASHING ALTERNATIVELY WITH THE "BATTERY" INDICATOR</p> <ul style="list-style-type: none"> ● System is in power-up delay period
BATTERY	<ul style="list-style-type: none"> ● Battery faulted 	<ul style="list-style-type: none"> ● Battery normal 	<ul style="list-style-type: none"> ● The battery is under testing <p>FLASHING ALTERNATIVELY WITH THE "AC POWER" INDICATOR</p> <ul style="list-style-type: none"> ● System is in power-up delay period
PROGRAM	<ul style="list-style-type: none"> ● System in program mode 	<ul style="list-style-type: none"> ● Normal state 	
ARM PROHIBITED	<ul style="list-style-type: none"> ● System in arm prohibited mode, indicator is ON during exit delay period 	<ul style="list-style-type: none"> ● System is armed after exit delay expired ● System in forced to arm mode 	<ul style="list-style-type: none"> ● The system can not be armed after exit delay expired due to faulty zone(s) existing, see zone indicator for the faulty zone(s)
DIALING	<ul style="list-style-type: none"> ● Dialing in DTMF format 	<ul style="list-style-type: none"> ● No dialing is in progress ● Dialing for duress after the duress code is entered 	<ul style="list-style-type: none"> ● Dialing in pulse format <p>FLASHING TWICE</p> <ul style="list-style-type: none"> ● The system is in telephone line fault testing
RECORDING	<ul style="list-style-type: none"> ● Voice recording is in progress 	<ul style="list-style-type: none"> ● No recording, or the recording time is expired 	

ARMING THE SYSTEM

TO ARM THE SYSTEM

- 1) Make sure that the alarm system is in disarmed state.
 - No alarm memory is existing on the zone indicators.

- 2) Enter your [user code] and validate by [#] key

USER CODE

#

- Your user code can be two to five digits long.
- Don't pause for more than 10 seconds while entering the digits or the control panel will reject your user code.
- If you make a mistake while entering the user code, the control console will give five beeps. After the beeps, enter your code again.
- The control console will give 2 beeps to confirm that the system is ON and exit delay has started, the EXIT/ARMED LED will flash.

- 3) Exit through the exit delay door

- The exit delay can be programmed from 2 to 999 seconds.
- Exit beep will be given if this program option is selected. Please put a "✓" in the box showing your selected option:

EXIT BEEP ENABLED ————— OPTION SELECTED (DEFAULT)

EXIT BEEP DISABLED ————— OPTION SELECTED

- The system will be armed after the exit delay expired, the EXIT/ARMED LED will be ON.

TO ARM THE SYSTEM INSTANTLY

- 1) Make sure the system is in disarmed state with no alarm memory shown on the zone LEDs.

- 2) Enter your [user code], press the [*] key, enter number [2], and validate by [#] key.

USER CODE

*

2

#

- The control console will give 2 beeps to confirm that the system is armed instantly.
- The EXIT/ARMED LED is ON.
- When the system is instantly armed, you will not be able to walk through any protected area. The control console must be installed outside the protected area.

TO ARM THE SYSTEM IN HOME MODE

Home mode will only arm the perimeter zones. Those interior zones stored in memory (*if any*) for home mode will be isolated when the system is armed.

1) Make sure the system is in disarmed state with no alarm memory shown on the zone LEDs.

2) **Enter your [user code], press the [HOME] key, and validate by [#] key.**

USER CODE

HOME

#

- The control console will give 2 beeps to confirm that the system is ON and exit delay has started, the EXIT/ARMED LED will flash.
- The isolated zone LEDs will flash all the time to indicate that the isolated zones are not protected.
- The system will be armed after the exit delay expired, the EXIT/ARMED LED will be ON.
- You are allowed to move about freely inside the premises that the interior protection zones are isolated while the system is armed.

TO ARM THE SYSTEM INSTANTLY IN HOME MODE

Home mode will only arm the perimeter zones. Those interior zones put in memory (*if any*) for home mode will be isolated when the system is armed.

1) Make sure the system is in disarmed state with no alarm memory shown on the zone LEDs.

2) **Enter your [user code], press the [HOME] key, enter number [2] and validate by [#] key.**

USER CODE

HOME

2

#

- The control console will give 2 beeps to confirm that the system is armed instantly, the EXIT/ARMED LED will be ON.
- The isolated zone LEDs will flash all the time to indicate that the isolated zone are not protected.
- You are allowed to move about freely inside the premises that the interior protection zones are isolated while the system is armed.

TO ARM THE SYSTEM WITH MANUALLY ISOLATED ZONE(S)

In some circumstances, making isolation to the protection zone(s) may be required, such as:

- To isolate the faulty zone(s).
- To isolate the zone(s) that is not the habitually isolation zone(s) in memory.
- To isolate the zone (*zone 8*) that the cabinet tamper switch is connected to prevent triggering of the alarm when the cabinet is opened for service purpose.

1) Make sure the system is in disarmed state with no alarm memory shown on the zone LEDs.

2) **Enter your [user code], press the [ISOLATE] key, enter the [ZONE NUMBER(S)] you wish to isolate and validate by [#] key.**

USER CODE

ISOLATE

ZONE NO.

ZONE NO.

ZONE NO.

#

- The isolating zone numbers can be entered continuously.
- The control console will give 2 beeps to confirm that the system is ON and exit delay has started, the EXIT/ARMED LED will flash.
- The isolated zone LEDs will flash all the time to indicate that the isolated zones are not protected.
- The system will be armed after the exit delay expired, the EXIT/ARMED LED will be ON.
- You are allowed to move about freely inside the premises that the interior protection zones are isolated, or to open the cabinet that the tamper switch is isolated while the system is armed.
- Making isolation to a 24-hour zone is dangerous and is not recommended, unless it is strictly necessary.
- The manually isolated zone(s) will be reset when the system is disarmed.

ARMING OPTIONS

Your alarm system has been programmed for one of the following arming types, please put a "✓" in the box showing your selected option:

FORCED TO ARM _____ **OPTION
SELECTED** (DEFAULT)

Any hardware zone (*zone 1 to zone 8*) that is violated after the EXIT DELAY time expired will be automatically isolated until the system is disarmed.

- The zone LEDs will light up to indicate the faulted (*isolated by the system*) zones.
- **WARNING:** The isolated zones are not protected.

ARM PROHIBITED _____ **OPTION
SELECTED**

If any hardware zone (*zone 1 to zone 8*) is faulted (*broken wire, open window, malfunctioning sensor, etc.*), you will not be able to arm the system until the faulted zone is cleared or manually isolated.

- Every time, when you switch ON the alarm system, the arm prohibited LED will be ON to remind you that **ARM PROHIBITED** is selected.
- The system will be armed after the EXIT DELAY time expired and the arm prohibited LED will be OFF if there is no faulted zone.
- The system will not be armed after the EXIT DELAY time expired, the arm prohibited LED will flash constantly and 5 beeps will be generated if any zone is faulted.
- You can isolate the faulted zone and arm the system by using the operation procedures **ARM THE SYSTEM WITH MANUALLY ISOLATED ZONES** stated previously.

TRIGGERING OPTIONS

Your system has been programmed for one of the following triggering mode for the people to enter the premises, please put a "✓" in the box showing your selected option:

HANDOVER DISABLED _____ **OPTION
SELECTED** (DEFAULT)

The system is in normal operation. All the protection zones can be triggered with their functions according to the zone configuration settings.

HANDOVER ENABLED _____ **OPTION
SELECTED**

In handover enabled condition, any delay zone is triggered first, all the instant zones will be disabled during the ENTRY DELAY time period, except the 24 hour protection zones.

With this feature, you can always set the motion sensors for interior protection with the INSTANT zones and the sensor for main door protection with the DELAY zone.

- The system will always give you ENTRY DELAY when you go in the premises from the main door entrance.
- The system will always give INSTANT ALARM to the people who enter the premises NOT from the main entrance, such as from the window, or any place that is protected by the instant zone. Usually that is a thief!

DISARMING THE SYSTEM AND TO CLEAR THE ALARM MEMORY

TO DISARM THE SYSTEM

In the condition of there is no alarm occurred when you come back from outside.

1) Enter the premises only through a **TIME DELAY door**. (DEFAULT: 30 seconds)

- If the entry beep is enabled, the control console will sound constantly until the ENTRY DELAY time expires, please put a "✓" in the box showing your selected option:

ENTRY BEEP ENABLED _____ OPTION SELECTED (DEFAULT)

ENTRY BEEP DISABLED _____ OPTION SELECTED

2) Enter your [USER CODE] and validate by [#] key within the ENTRY DELAY time period.

USER CODE

#

- The EXIT/ ARMED LED will go OFF and 2 beeps will be heard. The system is disarmed.
- If wrong code is entered, 5 beeps will be generated. Enter your user code again after the 5 beeps.

TO DISARM THE SYSTEM AFTER AN ALARM OCCURS

Enter your [USER CODE] and validate by [#] key.

USER CODE

#

- This will silence the siren/bell and disarm the system.
- The ZONE LEDs on the control console will flash to help you to remember where the violations occurred.
- The alarm memory can be kept as long as you like before you arm the system again.

TO CLEAR THE ALARM MEMORY

It is necessary to clear the alarm memory before you can re-arm the system.

Enter your [USER CODE], press the [*] key, enter number [3] and validate by [#] key.

USER CODE

*

3

#

- The zone LEDs with alarm memory will be OFF to show that the alarm memory has been cleared.
- The system keeps in disarmed mode.
- The system is ready for rearm anytime.

TO CLEAR THE ALARM MEMORY AND RE-ARM THE SYSTEM IN ONE TIME

The following command can help you to clear the alarm memory and at the same time to re-arm the system.

Enter your [USER CODE], press the [*]key, enter number [6] and validate by [#] key.

USER CODE

*

6

#

- The zone LEDs with alarm memory will be OFF to show that the alarm memory has been cleared.
- The control console will give 2 beeps to confirm that the system is ON and EXIT DELAY is started, the EXIT/ARMED LED will flash.
- The system will be armed after the EXIT DELAY expired, the EXIT/ARMED LED will be ON.

24-HOUR MONITORING AND ALARM REPORTING

The following options are available for alarm reporting. With the option selected, the system will transmit the alarm signal and/or voice message to the monitor station and/or to the telephones programmed accordingly when alarm occurs or when operation status changes.

Please put a "✓" in the box showing your selected option:

COMMUNICATOR AND VOICE DIALER "OFF" _____ OPTION
SELECTED

With this option selected, no status report or voice message will be sent.

COMMUNICATOR AND VOICE DIALER "ON" _____ OPTION
SELECTED

With this option selected, both status report and voice message will be sent when alarm occurs.

COMMUNICATOR "OFF", VOICE DIALER "ON" _____ OPTION
SELECTED (DEFAULT)

With this option selected, only voice message will be sent when alarm occurs.

COMMUNICATOR "ON", VOICE DIALER "OFF" _____ OPTION
SELECTED

With this option selected, only status report will be sent when alarm occurs.

EMERGENCY CASES

TO MAKE A PANIC ALARM

At anytime, hold down any TWO key buttons on the control console simultaneously for three seconds will trigger an alarm. The console will give 2 beeps to confirm the alarm condition.

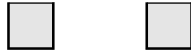

ANY TWO KEY BUTTONS ON THE CONTROL CONSOLE

- Local alarms will be given.
- Communicator (*if enabled*) will send a panic alarm report.
- The dialer (*if enabled*) will contact the programmed telephone numbers and send the message.
- There will be no indication of an alarm condition on the control console.

TO MAKE A DURESS ALARM

This feature is available **ONLY** at the condition that the communicator or the dialer is enabled. Otherwise, making a duress alarm is not possible.

Should an intruder force you to turn your security system **OFF**, you can send a silent DURESS alarm signal to the monitor station and send the recorded message to the programmed telephones.

The duress code is made by adding 2 to the 1st digit of your USER CODE(s). For example, if your User Code is [1357], enter [3357] will trigger a silent alarm (*Duress*).

Enter your [DURESS CODE], and validate by [#] key.

DURESS CODE

#

- No local alarm will be given.
- Communicator will send a duress alarm report.
- The dialer will contact the programmed telephones and send the message.
- There will be no indication of an alarm condition on the control console.
- The system will be turned **OFF** if it is in **ARMED** or in **ALARM MEMORY** condition.
- The system will keep itself in **OFF** condition if it is **OFF**.

TESTING YOUR SYSTEM

Please make sure that the system is in *DISARMED* mode when you perform the tests.

STANDBY BATTERY TESTING ROUTINES

The system can be programmed to perform dynamically and automatically test of its standby battery with the options of periodic test and manual test.

- The test takes 2 minutes. The **BATTERY** LED will flash during the test.
- AC power is turned OFF in order to monitor the battery under load during the test.
- Two beeps will be generated and the **BATTERY** LED will be OFF if the battery is normal.
- If the battery is low or dead, five beeps will be generated, the **BATTERY** LED will be ON. The control console will continuously generate the warning signal of one short beep per 30 seconds until the next test.
- A battery status report will be sent to the monitor station on the following two testing results if the communicator is enabled:
 - 1) The battery is **LOW** —————→ A battery **LOW** report.
 - 2) The battery resumes **NORMAL** but it was **LOW** —————→ A battery **NORMAL** report.

No report will be given if the battery is normal in this test and it was also normal in the last test.

NOTE:

- 1) The system will refuse to initiate the standby battery dynamic test in alarm condition, or, in the condition of AC power failure, but the system will send a battery low report automatically before battery exhausting if the battery is **LOW** lasting for more than two minutes.
- 2) The standby battery should be replaced every three to five years with a rechargeable 12V, 6.5AH, sealed lead-acid battery.

STANDBY BATTERY TEST -- PERIODIC

The system can be programmed with the following options for periodic standby battery test, please put a "✓" in the box showing your selected option:

DAILY (EVERY 24 HOURS) BATTERY TEST ENABLED ——— OPTION
SELECTED

WEEKLY (EVERY 7 DAYS) BATTERY TEST ENABLED ——— OPTION
SELECTED

PERIODIC BATTERY TEST DISABLED ————— OPTION
SELECTED (DEFAULT)

- The counting of the periodic test starts at the time when the system is power-up (*when AC or DC power is firstly connected*).
- The time counting of the periodic test is not affected by the manual battery test.

STANDBY BATTERY TEST -- MANUAL

It is highly recommended to manually test the standby battery from time to time if periodic battery test is not enabled.

In some cases, manual test of the standby battery is necessary even periodic test is enabled. Such as:

- To re-test the battery after charging for a period of time. The battery low indicating LED and the beep sound will be reset after test if the battery which resumes normal was **LOW**.
- To test a newly replaced battery and to reset the battery low indications - both the beep sounds and the LED light.
- Manual test can be performed at anytime you like.

Enter your [USER CODE], press the [*] key, enter number [4] and validate by [#] key.

USER CODE

*

4

#

- Dynamic battery test starts.
- Manual test and periodic test take the same testing routines.

TESTING THE LOCAL ALARM OUTPUTS

It is highly recommended to test the alarm outputs of your system from time to time to make sure that the siren/bell and the strobe light are working properly.

Enter your [USER CODE], press the [*] key, enter number [5] and validate by [#] key.

USER CODE

*

5

#

- The alarm output relays connected to the bell/siren, satellite siren and the strobe light will activate for 3 seconds.
- Nothing happen to the communicator and dialer.

TESTING THE TELEPHONE NUMBERS IN COMMUNICATOR AND AUTO-DIALER

To ensure the alarm reporting capability of the communicator and the auto dialer of your system in good order, it is recommended to test the telephone numbers in each of their locations one by one by sending a current status report or the recorded message to the appropriate receiving parties.

- Please inform the appropriate receiving parties beforehand when you make the tests.
- The system will refuse your test if the communicator or the auto dialer is not enabled, or no telephone number is stored in the location that is going to be tested.

Enter your [USER CODE], press [*], Enter the [TELEPHONE LOCATION], validate by [#].

To initiate main monitor station test --- COMMUNICATOR TELEPHONE NO.1

USER CODE * 50 #

To initiate backup monitor station test --- COMMUNICATOR TELEPHONE NO.2

USER CODE * 51 #

To initiate auto dialer 1st telephone test --- DIALER TELEPHONE NO.1

USER CODE * 60 #

To initiate auto dialer 2nd telephone test --- DIALER TELEPHONE NO.2

USER CODE * 61 #

To initiate auto dialer 3rd telephone test --- DIALER TELEPHONE NO.3

USER CODE * 62 #

To initiate auto dialer 4th telephone test --- DIALER TELEPHONE NO.4

USER CODE * 63 #

- The system will generate two beeps if test is accepted.
- The system will generate five beeps if test is refused due to function disabled or no telephone number stored.
- The communicator will send the current status report for monitor station testing.
- The auto dialer will send the recorded message for telephone testing.
- The system will only activate the telephone number that is initiated for testing. There is nothing happened to other numbers.
- The telephone number will dial only once in each testing even its program option in dialing attempt is more than one.

RECORDING THE ALARM REPORTING MESSAGE FOR AUTO-DIALER

The recording message for alarm reporting can be changed at any time you like to better reflect the situation of your alarm system.

The procedures for message recording are as follows:

1) Enter your [MASTER CODE] and validate by [*] [*]

MASTER CODE * *

- The **PROGRAM** light comes ON.
- System is in programming mode.

2) a) **HA-982S**

Press [RECORD] and validate by [#] key on the panel

RECORD #

- The **RECORD** light comes ON. It will last for 20 seconds
- The microphone is equipped on the panel.

b) **HA-982R**

Opening of the metal cabinet is necessary for making message recording to system HA-982R. As the [RECORD] button and microphone are equipped inside. The tamper switch in the cabinet is disabled and will not cause alarm while the system is on **PROGRAM** mode.

Press the [RECORD] button once.

(The button can be found on the main printed circuit board. It validates for recording instantly. Press the [#] key is not required.)

RECORD

- The **RECORD** light on printed circuit board comes ON. It will last for 20 seconds.
- The microphone is on the printed circuit board.

3) When the **RECORD** light is ON, speak to the microphone with your face about 30cm (1ft) from it. The light will be OFF when the 20 seconds expired and your message is stored.

4) Recording can be repeated as many times as you like until the message is in your satisfaction. The newly recorded message replaces the old one.

Repeat procedures 2 and 3 for recording repeats.

5) Exit the programming mode by pushing [*] [*].

* *

- System is back to operation mode.

6) Try to test and listen to the newly recorded message by initiating auto dialer telephone test with one of the telephone numbers.

Testing can be made easier if you possess a portable telephone and a portable AM/FM radio. For testing purposes, you can temporarily program your portable telephone's number in one of the locations (61-63) in the auto-dialer section, and switch the AM/FM radio on to play softly and put it about two meters (6 feet) away from the dialer. This way you can monitor the recorded message and the listen-in function without bothering anyone.

CHANGING A MASTER CODE

The master code is the authorization code for setting the system into programming mode. Please always keep this code for your own use only.

1) Enter your current [MASTER CODE] and validate by [*] [*]

MASTER CODE * *
CURRENT

- The **PROGRAM** light comes ON and system is in programming mode.

2) Enter the master code location [01], key in your new [MASTER CODE] and validate by [#]

01 MASTER CODE #
NEW

- The master code is accepted, it can be 2 to 5 digits.
- If the programming is rejected, 5 beeps will be generated. Try again.

3) Exit the programming mode by pushing [*] [*]

* *

- System is back to operation mode.

CHANGING A USER CODE

The system can store up to 8 user codes at Locations 11-18. All user codes are user programmable. Please always keep user code 1 for your own use as it is the only user code that can be used for remote arm-disarm control of the system from a tone dialing telephone.

IMPORTANT NOTE:

It is important that the new user codes will not fall into the duress code of other user codes. Please see **INSTALLATION MANUAL** Location 11-18 for more information.

1) Enter your [MASTER CODE] and validate by [*] [*]

MASTER CODE * *

- The **PROGRAM** light comes ON.

2) Enter the user code location [11-18] you wish to change its user code, key in the new [USER CODE] and validate by [#].

USER CODE LOCATION USER CODE #
NEW

- The new user code is accepted, it can be 2 to 5 digits.
- If the programming is rejected, 5 beeps will be generated. Try again.

3) Exit the programming mode by pushing [*] [*]

* *

- System is back to operation mode.

DELETING A USER CODE

8 user code locations are available in the system but putting user codes into all of them is optional. A user code in a location can be changed or deleted at anytime you like.

1) Enter your [MASTER CODE] and validate by [*] [*]

MASTER CODE * *

- The **PROGRAM** light comes ON.

2) Enter the user code location [11-18] you wish to deleted its user code and validate by [#]

USER CODE LOCATION #

- The user code in that location is deleted.
- If the request is rejected, 5 beeps will be generated. Try again.

3) Exit the programming mode by pushing [*] [*]

* *

- System is back to operation mode.

CHANGING A TELEPHONE NUMBER IN AUTO-DIALER

The telephone numbers in both communicator and auto dialer can be changed or deleted if required. The telephone number entry for communicator is usually handled by the installer or by the technician of the monitor station. Details are described in the INSTALLATION MANUAL, programming locations 50-51.

The telephone numbers that you put in the auto dialer are usually the numbers of your friends, relatives, your home/office phone, and even your portable phone or pager, you may change the numbers from time to time. The 4 telephone numbers are stored at locations 60-63.

1) Enter your [MASTE CODE] and validate by [*] [*]

MASTER CODE * *

- The **PROGRAM** light comes ON.

2) Enter the telephone location [60-63] you wish to change its telephone number, key in the message form [0 or 1] required, enter the new [TELEPHONE NUMBER] and validate by [#].

TELEPHONE LOCATION 1 TELEPHONE NUMBER #

NEW

- The new telephone number is accepted. It can be 32 digits maximum.
- The message form is **1, VOICE MESSAGE**. (If you wish the system to contact an auto-pager, the message form **0, NUMERIC MESSAGE** should be selected. Please see *INSTALLATION MANUAL*, "**Dialing to an auto-pager station from the dialer**" for details).
- If the programming is rejected, 5 beeps will be generated. Try again.

3) Exit the programming mode by pushing [*] [*]



- System is back to operation mode.

DELETING A TELEPHONE NUMBER IN AUTO-DIALER

If a telephone number is no longer valid for alarm reporting, and you do not have a new number to replace it, it is best to delete it. The auto dialer will skip the empty location to speed up the dialing attempt cycles.

1) Enter your [MASTER CODE] and validate by [*] [*]



- The **PROGRAM** light comes ON.

2) Enter the telephone location [60-63] you wish to delete its telephone number and validate by [#].



- The telephone number in that location is deleted.
- If the request is rejected, 5 beeps will be generated. Try again.

3) Exit the programming mode by pushing [*] [*]



- System is back to operation mode.

ALARM REPORTING AND ACKNOWLEDGEMENT

- In alarm condition, except the local alarm, the system will also send alarm report to the monitor station and the recorded message to the programmed telephones if the communicator and the auto dialer are enabled.
- The communicator has the priority to dial. After the communicator dialing is finished, the system will start to dial the telephone numbers stored in the auto dialer.
- If **VOICE MESSAGE** is selected, the auto dialer will send the recorded message after the line is through.

RECEIVING AN ALARM REPORTING MESSAGE AND GIVING ACKNOWLEDGEMENT

Please put a "✓" in the box showing your selected option:

NON-BACKUP REPORTING _____ OPTION
SELECTED (DEFAULT)

BACKUP REPORTING _____ OPTION
SELECTED

- 1) When you pick up the phone, you will hear the recorded alarm reporting message (20 seconds). At the end of the message, the dialer generates a BEEP tone and then waits 3 seconds for you to acknowledge.
- 2) The acknowledgement signal can be given by pressing the [1] button on your telephone (*it must be a tone dialing telephone*) after the BEEP within 3 seconds.

1 - - - - - ON YOUR TELEPHONE KEYBOARD

- 3) Without an acknowledgement, the message will be repeated until the maximum number of message is reached. The dialer will call the remaining numbers and will then retry the numbers that did not acknowledge repeatedly until the maximum number of dialing attempts are reached.
- 4) On **BACKUP** reporting mode, receiving an acknowledgement signal from a SINGLE telephone in a group of 4 (*the dialer can store 4 telephone numbers maximum*) is sufficient to consider the current event closed and call off the dialer session. The remaining 3 telephones are there for backup purposes only.
- 5) On **NON-BACKUP** reporting mode, an acknowledgement signal must be received from each telephone in the group of 4 (*if 4 numbers are stored*) before the current event is considered to be reported and closed.

INITIATING THE LISTEN-IN FUNCTION

Please put a "✓" in the box showing your selected option:

LISTEN-IN ENABLED _____ SECONDS (DEFAULT: 60 SECONDS)

LISTEN-IN DISABLED _____ OPTION
SELECTED

- 6) At the end of the message, the dialer waits 3 seconds for you to acknowledge (*An DTMF "1" signal is required*). Upon receipt of the acknowledgement signal, the dialer removes the presently contacted telephone from its task list for the current event in the manner of listen-in disabled.
- 7) If listen-in function is permitted (*enabled*), the dialer enables the listen-in for a preset period of time after acknowledgement.
- 8) At the end of the listen-in period, a short BEEP is generated. If you key in [1] again within 10 seconds, a new listen-in period begins. Without keying [1], the dialer will go **on hook**. The listen-in period may be prolonged as many times as necessary or terminated the function immediately after the short BEEP by keying in [9] from your telephone.

1 - - - - - TO INITIATE A NEW LISTEN-IN PERIOD

9 - - - - - TO TERMINATE THE LISTEN-IN FUNCTION IMMEDIATELY

- 9) The listen-in function allows you to listen to the protected premises with your telephone. The on-board microphone of the Alarm system is enabled during the listen-in period.

REMOTE ACCESS THE SYSTEM BY TELEPHONE

The HA-982 has been designed to allow the owner to telephone the system remotely (See *Program Location 83 for details*) to check its arm-disarm status, to make arm-disarm control or to request the communicator for a current status report sending to the monitor station or to the owner's pocket pager. The call can be made from any telephone capable of tone dialing, including DTMF capable mobile telephones.

Please put a "✓" in the box showing your selected option:

REMOTE ACCESS ENABLED _____ RINGS TO PICK-UP LINE (DEFAULT: 16)

REMOTE ACCESS DISABLED _____ OPTION SELECTED

CHECKING THE ARM-DISARM CURRENT STATUS

1. Ring the number that the system is connected to. In most cases that is the home telephone number of the owner.
2. After the pre-set number of rings (*programmed at Location 83. DEFAULT: 16*) the system will answer the phone with one of the following answering beeps to show its current status.

THE MEANING OF THE ANSWERING BEEPS--SUMMARY

NO.	ANSWERING BEEPS	MEANINGS
1	1 beep	● System is disarmed
2	2 beeps	● System is armed
3	1 beep + 3 beeps	● System is disarmed, but ● Alarm is occurred (<i>due to the 24 hours or the software zones</i>)
4	2 beeps + 3 beeps	● System is armed, and ● Alarm is occurred
5	1 beep + 2 beeps	● System is disarmed, but ● System is in alarm memory, at least one of the protection zones was in alarm
6	5 beeps	● Unsuccessful code entry, try again
7	2 beeps + 5 beeps	● Successful code entry but the function request is rejected due to system arm prohibited

3. If you only wish to check on the CURRENT STATUS of the alarm system, without making any change, simply hang up the phone after the answering beep is heard.

REMOTE ARM-DISARM THE SYSTEM

4. If you wish to change the status on the system, please enter the appropriate command code using the telephone keypad after the answering beep is heard.

NOTE: For obvious security reasons **ONLY USER CODE 1** can be used for system remote ARM-DISARM control.

a) If the answering beep is **1 BEEP**, system is in disarmed state.

Enter [USER CODE 1] and validate by [#]

USER CODE 1 #

- The system is armed instantly.
- **2 BEEPS** will be heard.

b) If the answering beep is **2 BEEPS**, system is in armed state.

Enter [USER CODE 1] and validate by [#]

USER CODE 1 #

- The system is disarmed instantly.
- **1 BEEP** will be heard.

c) If the answering beep is **1 BEEP+3 BEEPS**, system is in disarmed state with alarm occurred.

Enter [USER CODE 1] and validate by [#]

USER CODE 1 #

- The system is still in disarmed state, alarm is reset instantly and changes to alarm memory.
- **1 BEEP+2 BEEPS** will be heard.

d) If the answering beep is **2 BEEPS+3 BEEPS**, system is in armed state with alarm occurred.

Enter [USER CODE 1] and validate by [#]

USER CODE 1 #

- The system is disarmed instantly, and changes to alarm memory.
- **1 BEEP+2 BEEPS** will be heard.

e) If the answering beep is **1 BEEP+2 BEEPS**, system is in disarmed state with alarm memory.

i) **Enter [USER CODE 1], key in [✱], enter [3] and validate by [#]-----To clear the alarm memory only.**

USER CODE 1 ✱ 3 #

- The system is still in disarmed state and the alarm memory is cleared.
- **1 BEEP** will be heard.
- The system is ready to re-arm with the entry of option (a) stated above.

ii) **Enter [USER CODE 1], key in [✱], enter [6] and validate by [#]-----To clear the alarm memory and re-arm the system.**

USER CODE 1 ✱ 6 #

- The alarm memory is cleared and the system is re-armed instantly.
- **2 BEEPS** will be heard.

NOTE:

- i) The system will terminate the session and hang up after the command is accepted.
- ii) The answering beep of **5 BEEPS** stands for unsuccessful command code entry, please try again. If four incorrect attempts are made, the system will terminate the session and hang up.
- iii) The answering beep of **2 BEEPS+5 BEEPS** stands for arm prohibited which means that the system can not be armed due to faulty zone(s) existing. The system will terminate the session and hang up after the beeps.

5. Hang up the telephone immediately to allow the communicator (*if it is enabled, please see INSTALLATION MANUAL Location 76 and 80 for details*) of the system to ring the monitor station as a result of armed or disarmed the system.

In case of **ARM PROHIBITED** or **FORCED TO ARM** occurred, the communicator will always ring the monitor station and will send a status report because it is a system problem.

The report will be sent 10 seconds after the answering beep is heard.

THE COMMAND CODES FOR REMOTE ACCESS CONTROL--SUMMARY

NO.	COMMAND CODES	MEANINGS
A	USER CODE 1 #	<ul style="list-style-type: none"> ● To arm the system if it is disarmed, or ● To disarm the system if it is armed
B	USER CODE 1 * 3 #	<ul style="list-style-type: none"> ● To clear the alarm memory and keep the system in disarmed mode
C	USER CODE 1 * 6 #	<ul style="list-style-type: none"> ● To clear the alarm memory and re-arm the system
D	CLIENT CODE #	<ul style="list-style-type: none"> ● Requesting the system to send a report of its currently registered status to the monitor station or to an auto-pager ● The report will be sent 10 seconds after the command code is successfully entered, 2 beeps will be generated to confirm successful code entry

REQUESTING A CURRENT STATUS REPORT

The communicator of the system has been designed to allow the authorized person (*usually the monitor station*) or the owner to call for a current status report.

- 1) Ring the number that the system is connected.
- 2) After the pre-set number of rings, the system will answer the phone with the answering beep(s) to show its current status.
- 3) **Enter the [CLIENT CODE] and validate by [#] using the telephone keypad.**

- 4) If the code entry is correct, two short beeps will be generated to confirm that the request will be done. Hang up the telephone immediately to allow the communicator to send the report. The report will be sent out to the monitor station and /or to the auto-pager 10 seconds after the confirmation beeps.
- 5) If a mistake is made on CLIENT CODE entry, press the [#] key (*5 beeps will be heard*) and try again. If four incorrect attempts are made, the system will terminate the session and hang up.

ARMING-DISARMING CONTROLS BY KEY SWITCH--OPTIONAL

The HA-982 has been prepared with the facility of connecting optional key switches for arm-disarm controls. If your system is equipped with the optional key switch, you can make arm-disarm controls from the key switch as like from the control console.

UTILIZE THE REMOTE KEY SWITCH FOR SYSTEM ARM-DISARM CONTROLS

ARM THE SYSTEM		
KEY SWITCH CONTACT	STATUS	RESULTS
1st Touch	<ul style="list-style-type: none"> ● Away mode arming 	<ul style="list-style-type: none"> ● Exit delay starts ● Exit beep sounds if it is enabled ● System will be armed after exit delay expired
2nd Touch	<ul style="list-style-type: none"> ● Home mode arming 	<ul style="list-style-type: none"> ● The 2nd touch must be made within the exit delay period ● Exit beep sounds continuously until the end of the exit delay ● System will be armed after exit delay expired
DISARM THE SYSTEM		
1st Touch	<ul style="list-style-type: none"> ● System disarmed 	<ul style="list-style-type: none"> ● The system is disarmed and reset if there was no alarm occurred. It is ready for re-arming ● The system is disarmed, but, with alarm memory if there was alarm occurred, 2nd touch is required
2nd Touch	<ul style="list-style-type: none"> ● Alarm memory is cleared ● System keeps in disarmed mode 	<ul style="list-style-type: none"> ● The alarm memory LEDs are off (<i>both the STATUS LED and the zone LEDs on the control console</i>) ● The system is ready for re-arming

THE LED LIGHT INDICATORS FOR REMOTE KEY SWITCH

INDICATOR	ON	OFF	FLASHING
HOME-AWAY	<ul style="list-style-type: none"> ● Away mode arming 	<ul style="list-style-type: none"> ● System disarmed 	<ul style="list-style-type: none"> ● Home mode arming
STATUS	<ul style="list-style-type: none"> ● Exit delay starts but there is unsealed zone(s), please check the zone connections ● System is armed after exit delay expired 	<ul style="list-style-type: none"> ● System disarmed 	<p>FLASHING SLOW</p> <ul style="list-style-type: none"> ● Exit delay starts and the zones are normal <p>FLASHING FAST</p> <ul style="list-style-type: none"> ● Zone is or was in alarm <p>FLASHING FAST WITH STOPPING INTERVAL</p> <ul style="list-style-type: none"> ● System is disarmed ● Zone with alarm memory

**8-ZONE ALARM CONTROL PANEL
WITH COMMUNICATOR AND AUTO-DIALER**

HA-982

INSTALLATION MANUAL



SINCE 1979



TABLE OF CONTENTS

PREFACE	3
INTRODUCTION	4
Alarm Reporting Chart	4
THE SYSTEM CONTROL CONSOLE AND ITS INDICATORS	5
The Sound Indicators	5
The LED Light Indicators	6
TERMINAL DEFINITIONS AND DESCRIPTIONS	7
The Terminals On Main Printed Circuit Board	7
Utilize Remote Key Switch For Arm-Disarm Controls	9
The Terminals On Control Console (HA-982R only)	12
Connecting The Input Power Cord (Optional - Version PT only)	12
FACTORY SETTINGS	13
The Purpose Of The Default Programming Setup	13
The Default Data Chart	13
PROGRAMMING THE PANEL	14
How To Enter Programming Mode	14
Use the factory set master code	14
Use your own master code	14
Use the DAP jumper Directly Access to Programming mode	14
Start The Programming	15
Recording the master code	15
Recording the client code	15
Recording the user codes	16
The duress code	17
Using the duress code	17
Configuration of the protection zones	18
Setting the exit delay time	19
Setting the entry delays	19
Setting the siren duration	19
Forced to arm or arm prohibited mode	20
Setting the handover function	20
Telephone numbers for communicator	21
Telephone numbers for auto-dialer	22
Putting pause to a telephone number	22
Why pause is necessary	23
When pause is required	23
Dialing to an auto-pager station from the auto-dialer	23
Sending an alarm report to your auto-pager from communicator	24
Sending voice message/alarm report via an PABX system	24
Dialing attempts for communicator	25

Dialing attempts for auto-dialer 25

Message repeats 26

Backup or non-backup reporting 26

Listen-in enable and duration 27

Arm-disarm report. 28

Selection of dialing combination 28

Selection of dialing mode for calling the telephone central office. 29

Numbering beep tones for control panel identification. 29

Number of rings to pick-up telephone line 30

Periodic report 31

Power-up delay 31

Periodic battery test 32

Dial tone and telephone line fault detects 32

Putting the habitual isolation zones in memory for HOME mode operation. 33

Recording the voice message. 33

Setting the system with default values 34

Exit The Programming Mode 34

PROGRAMMING SUMMARY CHART. 35

COMMUNICATOR'S ALARM-STATUS REPORT FORMAT 39

 Description Of The Report Parameters 40

 Client ID. 40

 User number 40

 Zone status 40

 System status 40

 Check sum 41

 The Acknowledgement Signal For Communicator 41

 Interpreting The Report - Examples 41

ALARM--SYSTEM STATUS--TESTING EVENTS REPORTING MEDIA SUMMARY CHART .. 42

ACCESS THE SYSTEM REMOTELY. 43

 The Meaning Of The Answering Beeps 43

 The Command Codes For Remote Access Control 43

 Remote Arm-Disarm The System By Telephone 44

 Call For A Status Report 45

THE AC AND BATTERY POWER 46

 AC Power Failure And Restoration 46

 Dynamic Battery Testing. 46

 Battery Low Indications And Auto Reset. 46

 Power Up Delay 47

 The Back-up Battery 47

GENERAL SPECIFICATION 47

OPENING THE CABINET FOR SERVICE 48

PREFACE

This installation manual is one of the two manuals for the HA-982 alarm control panel. This manual explains all the aspects in programming, connection terminal functions and the system features. All system parameters and options are described in detail.

To get most from the alarm system, we suggest that you take time to read through this manual and familiarize yourself with the system and its many outstanding features.

The operational procedures of the alarm system are described in the **Operator's Manual**.

INTRODUCTION

HA-982 is a smart alarm control panel with 8 protection zones, which is designed for home and office protections using the latest security concepts. The system is built-in with auto-dialer and communicator in one unit. When alarm occurs, it gives local alarm warnings as like the traditional alarm systems, and it also sends out voice message to the pre-set telephones, numeric message to the auto-pagers and an alarm report to a proprietary monitor station which is equipped with your own or the AEI's Alarm-Monitor software.

HA-982 control panel is compatible with all kinds public telephone systems.

ALARM REPORTING CHART

OFFICE, HOME, FACTORY,
WAREHOUSE, SHOP, ETC.

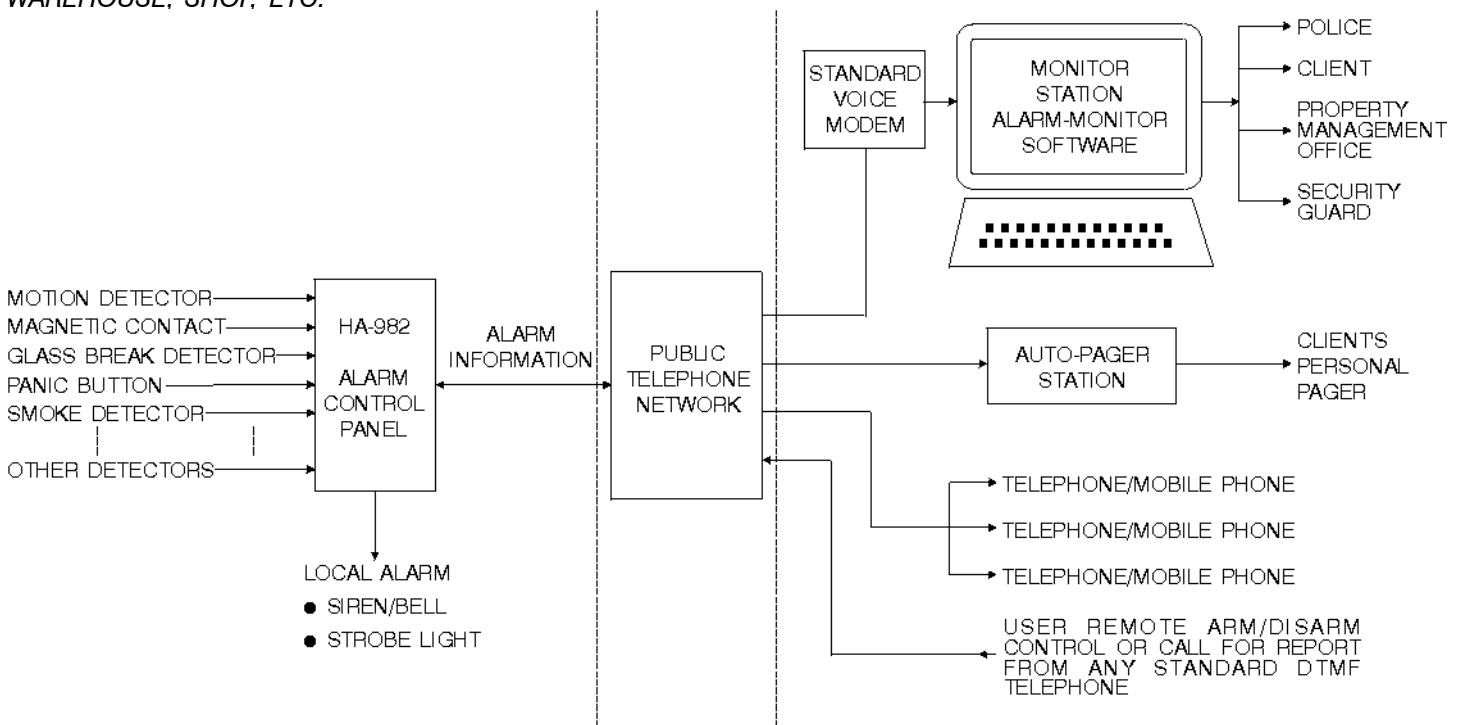

THE SYSTEM CONTROL CONSOLE AND ITS INDICATORS

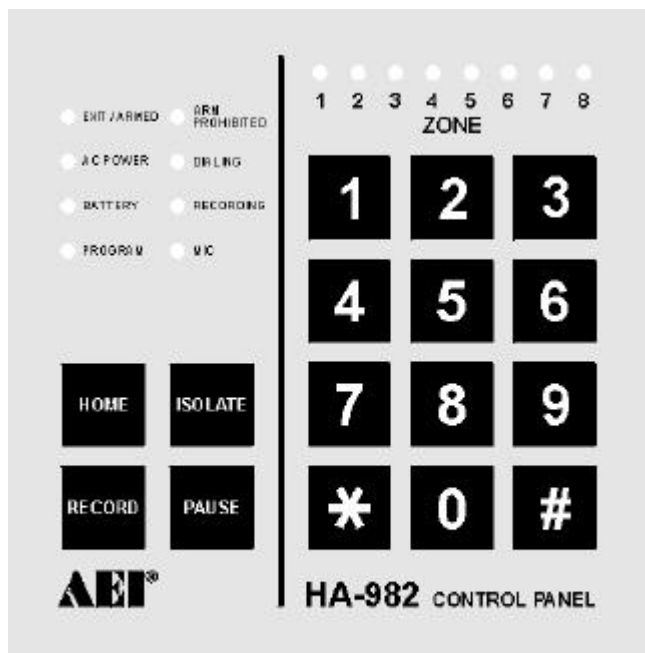

HA-982S

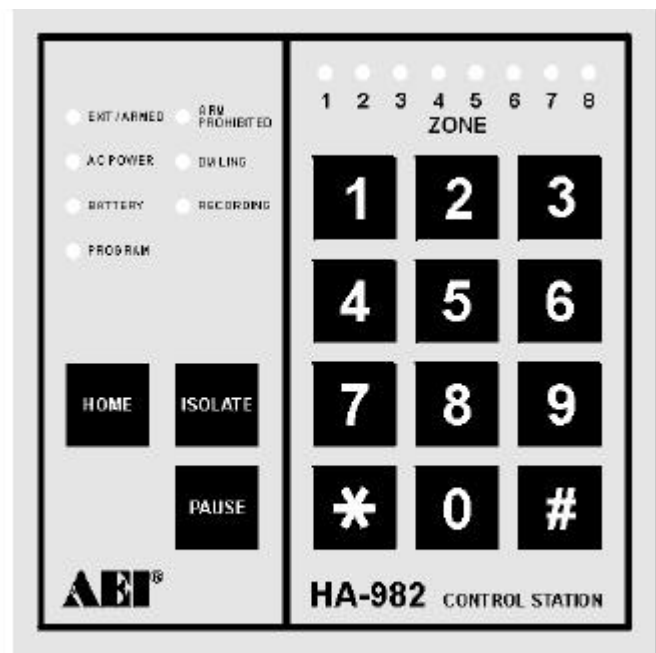

HA-982R

THE SOUND INDICATORS

SOUND	MEANING
1 short beep	<ul style="list-style-type: none"> ● Successful key entry, a pacifier tone
2 short beeps	<ul style="list-style-type: none"> ● Successful code entry for the specific function
5 short beeps	<ul style="list-style-type: none"> ● Unsuccessful code entry for the specific function ● Wrong code number entered ● Unauthorized command attempted ● Code entry time expired, 10 seconds maximum per digit is allowed
1 long beep	<ul style="list-style-type: none"> ● Exit delay expired, system is armed
1 short beep/30 seconds	<ul style="list-style-type: none"> ● AC power failure ● Battery low
Continuous beeping at 0.5 second interval	<ul style="list-style-type: none"> ● Exit delay time ● Entry delay time ● The DAP jumper is ON
Continuous 5 short beeps/5 seconds interval	<ul style="list-style-type: none"> ● The telephone line is faulty after line fault testing
2 beeps + 5 beeps	<ul style="list-style-type: none"> ● System can not be armed instantly due to ARM PROHIBITED ● Duress code is entered but the communicator is not working

THE LED LIGHT INDICATORS

INDICATORS	ON	OFF	FLASHING
ZONES (8 LEDs)	<ul style="list-style-type: none"> ● Zone unsealed (<i>faulted</i>) Please check the zone connections 	<ul style="list-style-type: none"> ● Zone sealed (<i>Normal</i>) 	<p>FLASHING FAST</p> <ul style="list-style-type: none"> ● Zone is or was in alarm <p>FLASHING FAST WITH STOPPING INTERVAL</p> <ul style="list-style-type: none"> ● Zone is in alarm memory, system is disarmed <p>FLASHING SLOW</p> <ul style="list-style-type: none"> ● Zone is isolated
EXIT/ARMED	<ul style="list-style-type: none"> ● Alarm armed 	<ul style="list-style-type: none"> ● Alarm disarmed 	<ul style="list-style-type: none"> ● In exit delay period
AC POWER	<ul style="list-style-type: none"> ● AC Power is being supplied 		<ul style="list-style-type: none"> ● AC power failure, system is using battery ● Flashing starts 20-30 seconds after AC power failure <p>FLASHING ALTERNATIVELY WITH THE "BATTERY" INDICATOR</p> <ul style="list-style-type: none"> ● System is in power-up delay period
BATTERY	<ul style="list-style-type: none"> ● Battery faulted 	<ul style="list-style-type: none"> ● Battery normal 	<ul style="list-style-type: none"> ● The battery is under testing <p>FLASHING ALTERNATIVELY WITH THE "AC POWER" INDICATOR</p> <ul style="list-style-type: none"> ● System is in power-up delay period
PROGRAM	<ul style="list-style-type: none"> ● System in program mode 	<ul style="list-style-type: none"> ● Normal state 	
ARM PROHIBITED	<ul style="list-style-type: none"> ● System in arm prohibited mode, indicator is ON during exit delay period 	<ul style="list-style-type: none"> ● System is armed after exit delay expired ● System in forced to arm mode 	<ul style="list-style-type: none"> ● The system can not be armed after exit delay expired due to faulty zone(s) existing, see zone indicator for the faulty zone(s)
DIALING	<ul style="list-style-type: none"> ● Dialing in DTMF format 	<ul style="list-style-type: none"> ● No dialing is in progress ● Dialing for duress after the duress code is entered 	<ul style="list-style-type: none"> ● Dialing in pulse format <p>FLASHING TWICE</p> <ul style="list-style-type: none"> ● The system is in telephone line fault testing
RECORDING	<ul style="list-style-type: none"> ● Voice recording is in progress 	<ul style="list-style-type: none"> ● No recording, or the recording time is expired 	

TERMINAL DEFINITIONS AND DESCRIPTIONS

THE TERMINALS ON MAIN PRINTED CIRCUIT BOARD

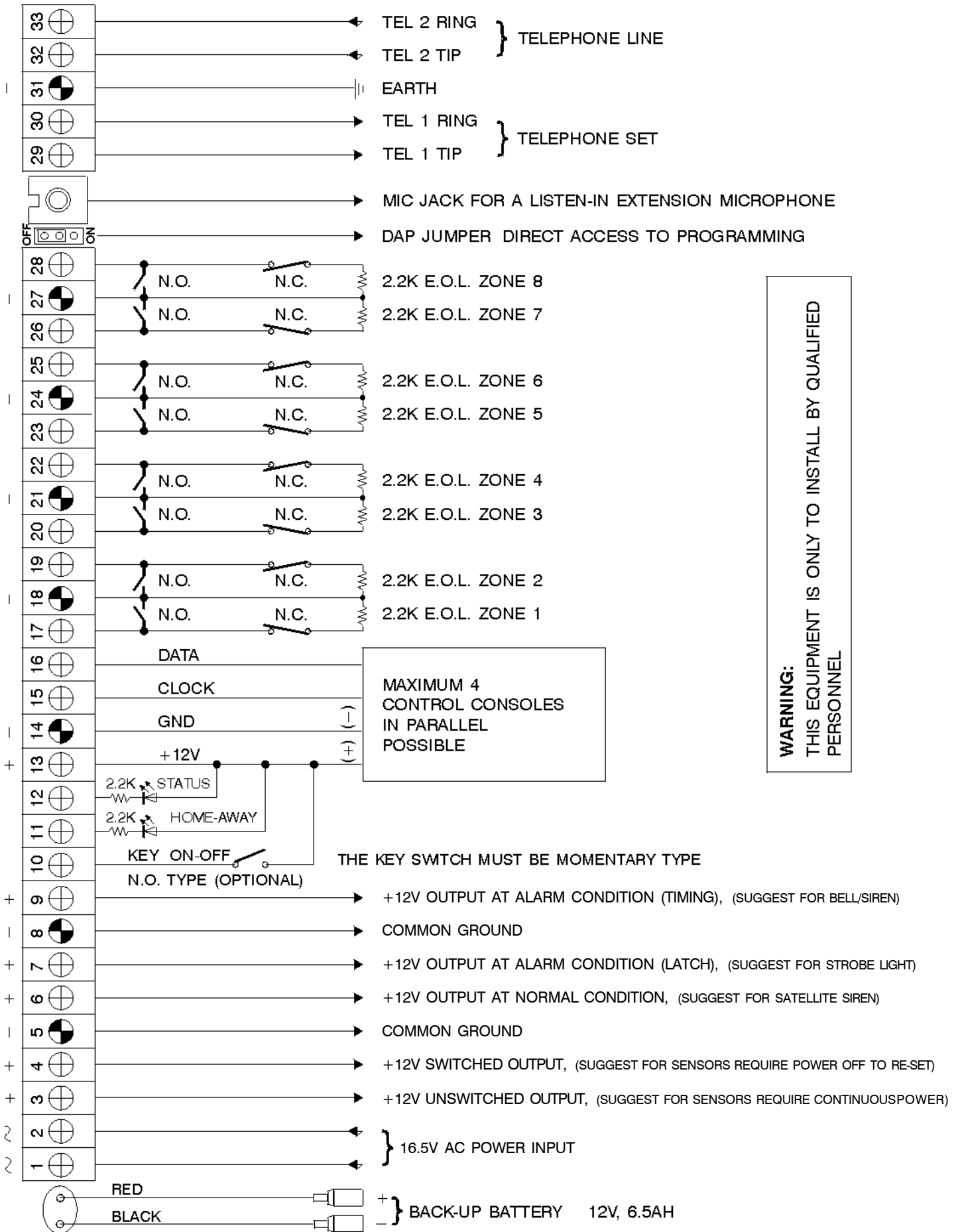

1, 2: AC Power is supplied from a 16.5V AC, 1.5Amp minimum transformer at 50 or 60Hz. The primary side of the transformer must be connected to an unswitched receptacle

NOTE: For the alarm control panel without built-in power transformer, the transformer to be used in this product must be complied in the EN61558 standard (*AEI Model: AP-980*).

3: This terminal provides an unswitched +12V output power referring to the common ground. It gives output power all the time no matter the system is armed or disarmed. Suitable for those devices require uninterrupted power supply. Such as smoke detectors, control keypads etc. This terminal is equipped with a 750mA resettable fuse.

4: This terminal provides a switched +12V output power referring to the common ground when the system is turned ON. The output voltage is OFF when the system is disarmed. It is prepared for devices that require switched power for resetting. Typical devices are glass-break detectors and some of the smoke detectors that require power OFF to reset. This terminal is equipped with a 750mA resettable fuse.

NOTE: Terminals 3 and 4 share the same power bus. Combined power for these outputs should not exceed 750mA.

5: Common Ground (-).

6: This terminal provides a continuous +12V output power at normal condition of no alarm occurred. Mostly suitable for the connection of Satellite Siren/Strobe Light (*AEI Model #ES-962A/B*). The +12V output is switched OFF at alarm condition. The output is equipped with a 2.5A resettable fuse.

REMARK: A Satellite Siren-Strobe Light unit is a self-contained device with built-in backup battery which is charged by the hold-off voltage from the control panel at normal condition. At which, the siren and strobe light are OFF.

At alarm condition, the hold-off voltage from the control panel is cut. The siren and strobe light at the unit start to work. They are supplied by the backup battery. The siren will stop when the pre-set time is expired, and that the strobe light will work until the hold-off voltage is resumed.

A Satellite Siren-Strobe Light is self-protected and tamper-proof. It gives alarm instantly if the connection wire between the unit and the alarm control panel is cut.

7: This terminal provides a continuous +12V output power at and after alarm condition until the system is disarmed or reset by the user code. It is mostly suitable for providing power for the stand alone strobe light or those devices require continuous operation at alarm condition after the siren timer is reset. The output is equipped with a 2.5A resettable fuse.

8: Common Ground (-).

9: This terminal provides +12V output power at alarm condition with the time period according to the setting of the alarm timer. It is suitable for energizing electronic siren or alarm bell. The output is equipped with a 2.5A resettable fuse.

10,11,12,13: This group of terminals are the connection points for a remote station using conventional key switch for alarm arm-disarm controls, which is prepared for those people do not like to use digital code, or who might forget the code in nervous when alarm occurs. Connection of key switch is optional. Maximum 5 remote stations with momentary type key switch (*AEI Model: RKS-2M*) can be connected in parallel to these terminals.

10: For connecting the momentary key switches.

11: For connecting the HOME-AWAY LED indicators.

12: For connecting the STATUS LED indicators.

13: The +12V power common point for the key switches and the LEDs. 750mA resettable fuse is equipped.

UTILIZE THE REMOTE KEY SWITCH FOR SYSTEM ARM-DISARM CONTROLS

ARM THE SYSTEM		
KEY SWITCH CONTACT	STATUS	RESULTS
1st Touch	<ul style="list-style-type: none"> ● Away mode arming 	<ul style="list-style-type: none"> ● Exit delay starts ● Exit beep sounds if it is enabled ● System will be armed after exit delay expired
2nd Touch	<ul style="list-style-type: none"> ● Home mode arming 	<ul style="list-style-type: none"> ● The 2nd touch must be made within the exit delay period ● Exit beep sounds continuously until the end of the exit delay ● System will be armed after exit delay expired
DISARM THE SYSTEM		
1st Touch	<ul style="list-style-type: none"> ● System disarmed 	<ul style="list-style-type: none"> ● The system is disarmed and reset if there was no alarm occurred. It is ready for re-arming ● The system is disarmed but with alarm memory if there was alarm occurred, 2nd touch is required
2nd Touch	<ul style="list-style-type: none"> ● Alarm memory is cleared ● System keeps in disarmed mode 	<ul style="list-style-type: none"> ● The alarm memory LEDs are off (<i>both the STATUS LED and the zone LEDs on the control console</i>) ● The system is ready for re-arming

THE LED LIGHT INDICATORS FOR REMOTE KEY SWITCH

INDICATOR	ON	OFF	FLASHING
HOME-AWAY	<ul style="list-style-type: none"> ● Away mode 	<ul style="list-style-type: none"> ● System disarmed 	<ul style="list-style-type: none"> ● Home mode
STATUS	<ul style="list-style-type: none"> ● Exit delay starts but there is unsealed zone(s), please check the zone connections ● System is armed after exit delay expired 	<ul style="list-style-type: none"> ● System disarmed 	<p>FLASHING SLOW</p> <ul style="list-style-type: none"> ● Exit delay starts and the zones are normal <p>FLASHING FAST</p> <ul style="list-style-type: none"> ● Zone is or was in alarm <p>FLASHING FAST WITH STOPPING INTERVAL</p> <ul style="list-style-type: none"> ● System is disarmed ● Zone with alarm memory

13,14,15,16: This group of terminals are the connection points for the system control console(s). All consoles should be connected in a parallel configuration back to these terminals and maximum 4 consoles can be allowed.

The system control console of the HA-982S is installed on the control panel unit, no connection is required. Just leave these terminals open unless additional remote console is required.

13: +12V power common point, equipped with a 750mA resettable fuse

14: Common ground (-)

15: Clock wire

16: Data wire

17,18,19,20, 21,22,23,24, 25,26,27,28: These terminals are protection zones 1 to 8 and their common grounding terminals. The zones are E.O.L. (*End of Line*) monitored by a 2.2K Ohm resistor.

All normally closed (N.C.) contacts are to be wired in series with the E.O.L. resistor, where all normally open (N.O.) contacts are to be wired in parallel with the E.O.L. resistor. The function of the zones and their response times are programmable via the system programming options.

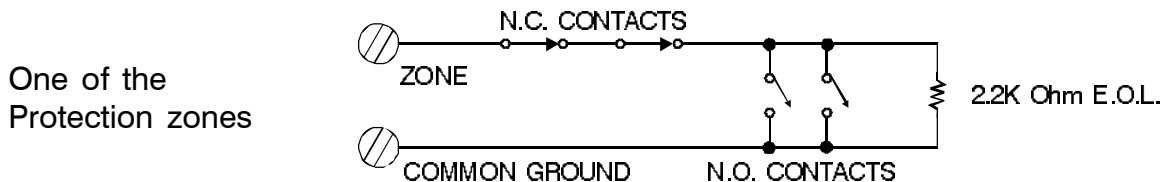

A protection zone with E.O.L resistor, either an open or a short will be reported as an alarm if the zone is in armed state.

17: Zone 1, **19:** Zone 2, **20:** Zone 3, **22:** Zone 4,

23: Zone 5, **25:** Zone 6, **26:** Zone 7, **28:** Zone 8,

18, 21, 24, 27: Common ground (-)

IMPORTANT NOTE: TAMPER SWITCH (N .C.)

The cabinet's tamper switch is pre-wired to zone 8 internally. Suggest always keep zone 8 programmed as a 24-hour protection zone.

- 29,30:** These two terminals are prepared for the connection of the house telephone set which is connected to the telephone line in normal condition. The house telephone set will be automatically disconnected from the telephone line whenever the communicator or the auto-dialer goes into action.
- 31:** This is the earth point of the system. This terminal should be connected to a nearest solid electrical earth point such as a cold water pipe or earth stake in order for it to provide protection against possible lightning interference. Use 14 gauge wire or larger for this connection. **Failure to earth the unit compromises safety!**
- 32,33:** These two terminals are prepared for connecting the incoming telephone line. The system connects the house telephone set to the telephone line in normal condition, and it picks up the line for the communicator or the auto-dialer whenever it goes into action.
- BATTERY:** The (+) RED wire connects to the positive terminal of the battery and the (-) BLACK wire connects to the negative terminal of the battery. The battery should be a 12V sealed lead acid rechargeable type with a capacity of 6.5AH. The battery is protected by a 3A resettable fuse, and it is charged by a current limiting regulated voltage source in the system.
- DAP JUMPER:** DAP stands for Direct Access to Programming. This jumper is prepared for setting the system into programming mode in case that the personal master code is forgotten.
- MIC JACK:** The built-in microphone on the control panel might not be sensitive enough for the listen-in function. Especially when the control panel is not installed in an open space.
- The MIC JACK is prepared for plugging in an extension microphone for listen-in purpose. The connection wire should be a shielded wire and the length should not be more than 30 feet (9m).
- The built-in microphone is disconnected when the extension microphone is plugged in the jack.
- Plugging in an extension microphone is optional.*
- D.T. JUMPER:** Two Dial Tones are commonly used at today's telephone central office, the continuous dial tone and the cadenced tone comprising the repeated sequence of ON and OFF of the tone.
- It is important to make the correct setting in your system to match the dial tone used at the telephone central office in your city. The D.T. JUMPER (Dial Tone Selection Jumper) can be found at the right hand side of the main circuit board. Put jumper on:
- 1) **CONT.** for continuous dial tone (*Factory put jumper on 1*)
 - 2) **CAD.** for cadenced dial tone
- Incorrect setting of the D.T. JUMPER may cause malfunction to the "Dial Tone & Line Fault Detects", or the "Ring Detect To Pickup Telephone Line On Remote Access" that you programmed.

THE TERMINALS ON THE CONTROL CONSOLE (HA-982R ONLY)

+	-			N.C.	
12V		CLOCK	DATA	TAMPER	

- (+) 12V:** +12V power input terminal, connect it to terminal 13.
- (-) 12V:** The common grounding point, connect it to terminal 14.
- CLOCK:** The clock line of the system, connect it to terminal 15.
- DATA:** The data line of the system, connect it to terminal 16.
- TAMPER N.C.:** These are the connection terminals of the tamper switch in the control console. Connection of it is optional. If connection is required, connect it to a normally closed (N.C.) 24-hour zone and zone 8 is suggested.

NOTE: The maximum wire length for connecting any control console is 500 feet (152m) of 22 AWG (0.643mm) copper wire. The system is capable to handle maximum 4 control consoles.

CONNECTING THE INPUT POWER CORD TO THE AC POWER TERMINAL BLOCK (Optional - For Version PT only)

- This alarm control panel comes with a built-in power transformer. Its Secondary side (16.5VAC) is connected to Terminals 1 and 2 of the main circuit board at the factory and that the Primary side is connected to an AC power terminal block which is prepared for the AC input power cord connection.

- Secure the AC input power cord firmly to the terminal block according to the indications below:

- L** : LIVE
- : EARTH (GROUND)
- N** : NEUTRAL

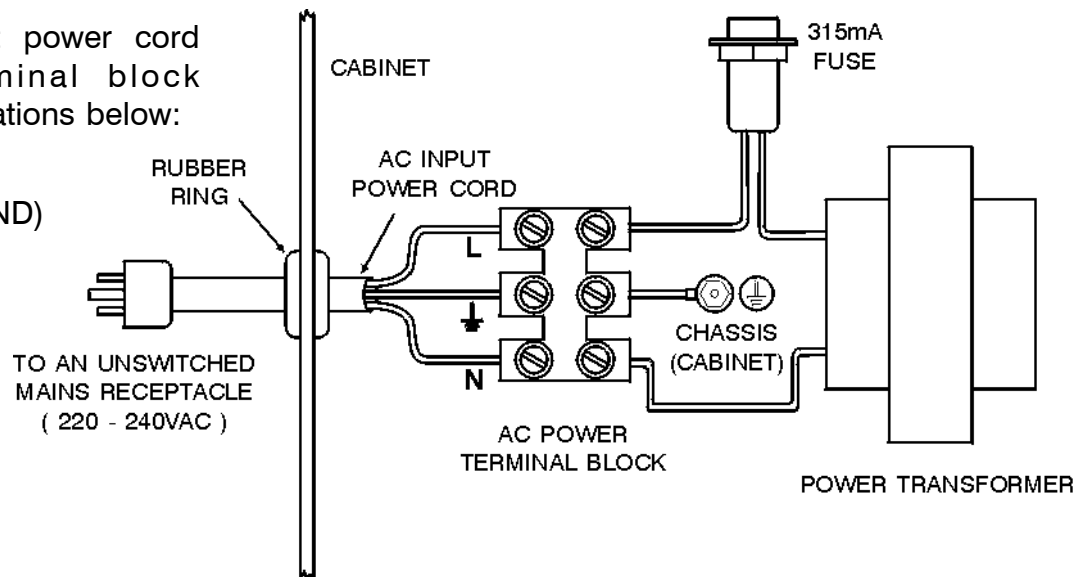

- Put the rubber ring (provided) on the feed through hole for the AC input power cord to prevent from scratch.
- The AC input power cord connecting to the Primary side of the power transformer **MUST** be connected to an unswitched Mains receptacle for continuous AC power.
- The power transformer is protected with a 315mA/250V fast blow glass fuse at the primary side. If fuse opens, remove AC and DC power, remove the short or overload condition, then replace the fuse before restoring power. **DO NOT** substitute a higher rated fuse.

FACTORY SETTINGS

The system has been programmed with the following default values before exit factory. The default values can be changed with the programming option values if they are not suitable for your application.

Please refer to *Programming the Panel* for details if re-programming is required.

THE PURPOSE OF THE DEFAULT PROGRAMMING SETUP

The default programming setup of the alarm system allows the owner to operate the system as a local alarm panel without programming except the **Master Code** and the **User Code**.

THE DEFAULT DATA CHART

PROGRAMMING LOCATION	PARAMETERS	DEFAULT VALUES	PROGRAM DATA
01	Master code	1234 (This is not a default value under the default programming operation. It is a value that factory put in the system before exit factory)	Code=1234
10	Client code	0000.	0000
11-18	User code 1-8	Nil	nil
21	Zone 1	Multiple trigger, Entry delay 1, 500mS response.	Code1=1,Code2=1,Code3=2
22	Zone 2	Multiple trigger, Entry delay 1, 500mS response.	Code1=1,Code2=1,Code3=2
23	Zone 3	Multiple trigger, Instant, 500mS response	Code1=1,Code2=0,Code3=2
24	Zone 4	Multiple trigger, Instant, 500mS response	Code1=1,Code2=0,Code3=2
25	Zone 5	Multiple trigger, Instant, 500mS response	Code1=1,Code2=0,Code3=2
26	Zone 6	Multiple trigger, Instant, 500mS response	Code1=1,Code2=0,Code3=2
27	Zone 7	Multiple trigger, 24-Hr Instant, 500mS response	Code1=1,Code2=3,Code3=2
28	Zone 8	Multiple trigger, 24-Hr Instant, 500mS response	Code1=1,Code2=3,Code3=2
30	Exit delay	Exit beep enabled, 60 seconds	Code=1, duration=60
31	Entry delay 1	Entry beep enabled, 30 seconds.	Code=1, duration=30
32	Entry delay 2	Enter beep enabled, 60 seconds.	Code=1, duration=60
33	Siren duration	Arm-disarm ring-back disabled,300 seconds	Code=0, duration=300
40	Arming type	Forced to arm	Code=0
41	Alarm handover	Disabled	Code=0
50-51	Telephone number for communicator	Nil.	nil
60-63	Telephone number for auto-dialer	Nil.	nil
70	Dialing attempts for communicator	4	Code=4
71	Dialing attempts for auto-dialer	4	Code=4
72	Recorded message repeats for auto-dialer	4	Code=4
73	Dialing backup/non-backup selection	Non-backup	Code=0
74	Listen-in period	60 seconds.	Duration=60
76	Arm-disarm report	Disable.	Code=0
80	Dialing combination	Communicator OFF, Voice dialer ON	Code=2
81	Dialing mode	Tone (DTMF)	Code=0
82	Alarm control panel numbering	Disabled.	Code=0
83	Number of rings to pick-up telephone line	16	Code=16
84	Periodic report	Disabled.	Code=0
HOME	Isolation zones in memory	Nil	nil
RECORD	Voice message recorded	Nil	nil
85	Power up delay	Disabled.	Code=0
86	Periodic battery test	Disabled.	Code=0
87	Dial-tone and line fault detects	Enabled	Code=1

PROGRAMMING THE PANEL

You can program the panel from the system control console. Firstly, you are required to make the system enters to programming mode, then key in the two digit *Programming Location or the address*, followed immediately by the desired programming values (*program data*), then press the [#] key to store the data. The console will beep twice to confirm the data is successfully stored, and that 5 beeps will be generated for unsuccessful data entry. If you are not sure that the correct programming values have been entered, program the programming location again. After programming is finished, press the [*] key twice to leave programming mode.

The maximum allowable time for each digit entry is 10 seconds.

ATTENTION:

To prevent triggering of the tamper switch, please make sure that the cabinet is firmly closed before applying power to the system. Also, do not install battery before the system is programmed. Otherwise, the tamper switch will be triggered instantly to give alarm before the door is closed, and there will be no user code available for turning off the alarm.

HOW TO ENTER PROGRAMMING MODE

1. USE THE FACTORY SET MASTER CODE

For the owner's convenience in programming at the first time, the factory has put a Master Code 1234 into the system. The owner can use this code for the system to enter to programming mode. To compromise security, in all cases, the owner should program a personal Master Code to invalidate the factory set Master Code.

FACTORY SET MASTER CODE	VALIDATION
1 2 3 4	* *

- The console will beep twice to confirm that the system is in programming mode.
- The **PROGRAM** LED is ON.

2. USE YOUR OWN MASTER CODE

In the case that the factory set Master Code was replaced by your own Master Code, you have to use your personal Master Code to enter to programming mode.

MASTER CODE	VALIDATION
MASTER CODE	* *

- The console will beep twice to confirm that the system is in programming mode.
- The **PROGRAM** LED is ON.

3. USE THE DAP JUMPER DIRECTLY ACCESS TO PROGRAMMING MODE

If the factory set master code was deleted and the personal master code is forgotten. Use the DAP jumper to override the forgotten code permitting direct entry into programming mode. The DAP jumper can be found on the master circuit board. The owner is required to apply the following procedures precisely when use the DAP jumper:

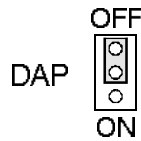

- i) Disconnect the power supply including both AC power and the back-up battery.
- ii) Displace the DAP jumper from OFF to ON position.
- iii) Reconnect the power supply, the console will beep continuously.
- iv) Put the DAP jumper back to OFF position, the beep stops and the **PROGRAM** LED is ON.
- v) The system is in programming mode now, and it is ready to receive new data.
- vi) The DAP jumper is normally left on OFF position after programming.

START THE PROGRAMMING

After the system is set in programming mode, you can start to program the system with your desired programming values. You can make the programming for all the program options continuously or just select those options that you require. It is not necessary to make the programming in order sequence; you can jump to any **Programming Location** that is available in the system.

RECORDING THE MASTER CODE

(Location: 01)

LOCATION	MASTER CODE	VALIDATION
0 1	2 TO 5 DIGITS	#

- The master code can be 2 digits minimum to 5 digits maximum.
- When the new personal master code is entered, the factory set master code or the code that was programmed will be erased.

RECORDING THE CLIENT CODE

(Location: 10)

LOCATION	CLIENT CODE	VALIDATION
10	4 DIGITS	#

- The client code is the client's identification number, it must be programmed with 4 digits. The system will reject the code if it is not exact 4 digits.
- The client code is not necessary if the alarm system is not linked to the monitor station.
- When a new code is entered, the old code will be replaced.
- The default value of the client code is 0000.

RECORDING THE USER CODES**(Locations: 11-18)**

LOCATIONS

11

USER CODES

2 TO 5 DIGITS

VALIDATION

#

- **LOCATIONS:**

11=User Code 1 (Also the code for remote control) **15=User Code 5**

12=User Code 2 **16=User Code 6**

13=User Code 3 **17=User Code 7**

14=User Code 4 **18=User Code 8**

- The user codes can be 2 digits minimum to 5 digits maximum.
- User code 1 is also the authorization code of the system to accept remote arm-disarm control from any DTMF telephone.
- Usually only one user code is required to arm-disarm the system.
- Programming of the user codes 2 to 8 is optional, unless more than one users are required to operate the alarm system.
- When a new code is entered into the location, the old code will be replaced.
- To invalid a code, just key-in the specific location number followed immediately by the [#] key without program data.

THE DURESS CODE

The duress code does not need to be programmed. The system determines it automatically by increasing the first digit of the user code(s) of **TWO** units. All 8 user codes can accept the entry for duress function.

Example: User Code 1328, Duress Code 3328
 or User Code 8312, Duress Code 0312
 or User Code 0856, Duress Code 2856

Important Notes:

- When program the system with more than one user codes, it is important that the user codes will not fall into the duress code of other user codes.
- For example, if user code 1 is 1328, it is not allowed to make other user code to 3328, as 3328 is the duress code of user code 1.
- The duress function only activates the communicator and the telephone dialer without activating of the local alarm outputs (*the siren & strobe*). Make sure that at least either the dialer or the communicator is enabled for reporting alarms. Otherwise, the duress code can give no function.

USING THE DURESS CODE

The following is the description of the duress code operation. It is not a programming procedure.

- To command the duress function, enter the duress code and validate via the [#] key.

DURESS CODE

#

- The duress code is valid at anytime no matter the system is armed or disarmed. The system exhibits the following behaviours when the duress code is entered.
- System behaviours:

BEFORE KEYING - IN THE DURESS CODE	AFTER KEYING - IN THE DURESS CODE
System was armed	System is disarmed and starts dialing for reporting alarm
System was disarmed	System is still disarmed and starts dialing for reporting alarm.

CONFIGURATION OF THE PROTECTION ZONES

(Location: 21-28)

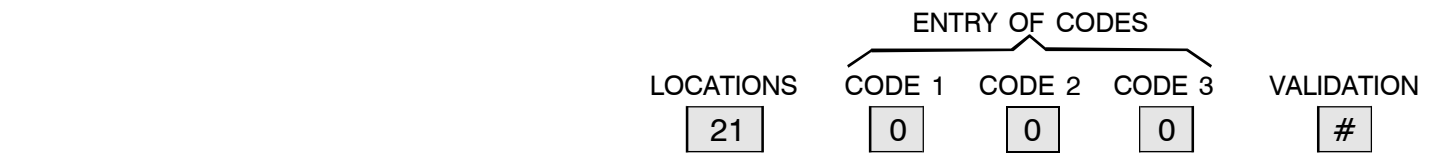

ZONE LOCATIONS

- 21=ZONE 1 22=ZONE 2
- 23=ZONE 3 24=ZONE 4
- 25=ZONE 5 26=ZONE 6
- 27=ZONE 7 28=ZONE 8

CODE 1--TRIGGERING MODE

- 0---SINGLE TRIGGER:** The zone can only give alarm once. It does not accept 2nd triggering to prevent noise pollution. The zone will be refreshed when the system is reset.
- 1---MULTIPLE TRIGGER:** (DEFAULT FOR ALL 8 ZONES)
The zone can be re-triggered after alarm was occurred if the system is still armed.

CODE 2--LOOP RESPONSE MODE

- 0---INSTANT:** The zone gives no entry delay and triggers the alarm instantly.
- 1---ENTRY DELAY 1:** The zone gives entry delay according to the time setting on the entry delay timer 1.
- 2---ENTRY DELAY 2:** The zone gives entry delay according to the time setting on the entry delay timer 2.

REMARK : The purpose of entry delay 1 and entry delay 2 is to provide operation convenience for the owner to reach the panel from different entrances of the house to disarm the system.
For example: entering the house from the garage usually requires more time than from the main door. With the help of 2 entry delays, the owner can set different entry delay times for the two entrances.

- 3---24-HOUR INSTANT:** The zone is always in standby mode, no matter the system is armed or disarmed. It gives instant alarm whenever it is triggered.
- 4---24-HOUR SILENT PANIC:** The zone is always in standby mode, no matter the system is armed or disarmed. It activates the communicator and telephone dialer but not the local alarm output (*no siren and strobe light*) whenever it is triggered. Make sure that either the dialer or the communicator is enabled for alarm reporting, otherwise, the zone gives no function and the zone LED will be ON showing that it is a faulty zone.

CODE 3--LOOP RESPONSE TIME

- Loop response time is the time required to trigger a protection Zone.
- 0 -- 25 mS 2 -- 500 mS (DEFAULT FOR ALL 8 ZONES)
 - 1 -- 250 mS 3 -- 750 mS

DEFAULT VALUES FOR CODE 2		
ZONE	CODE 2	RESPONES
1	1	ENTRY DELAY 1
2	1	ENTRY DELAY 1
3	0	INSTANT
4	0	INSTANT
5	0	INSTANT
6	0	INSTANT
7	3	24-HR INSTANT
8	3	24-HR INSTANT

SETTING THE EXIT DELAY TIME

(Location: 30)

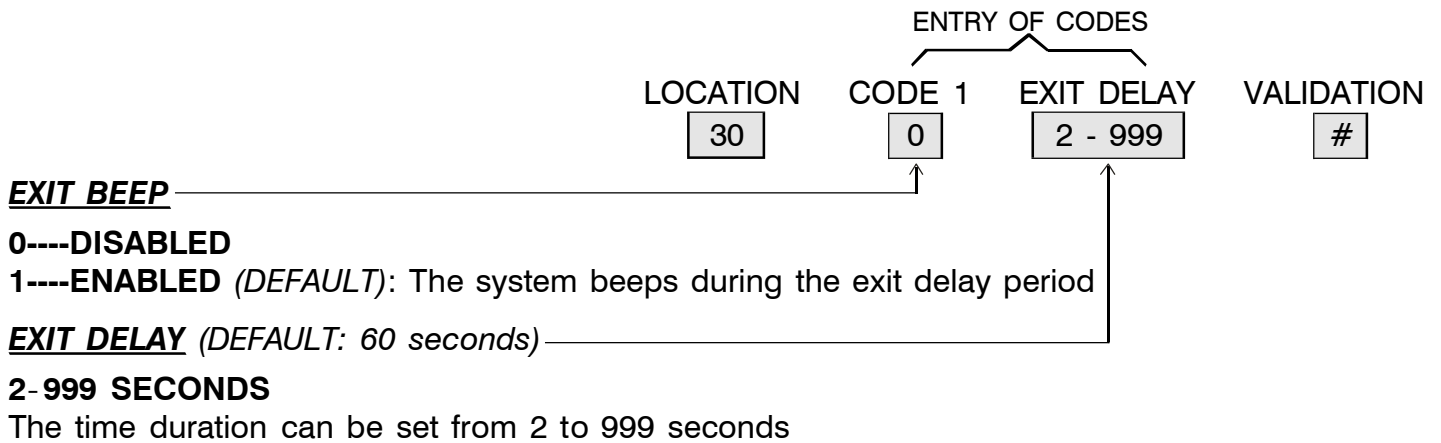

SETTING THE ENTRY DELAYS

(Location: 31-32)

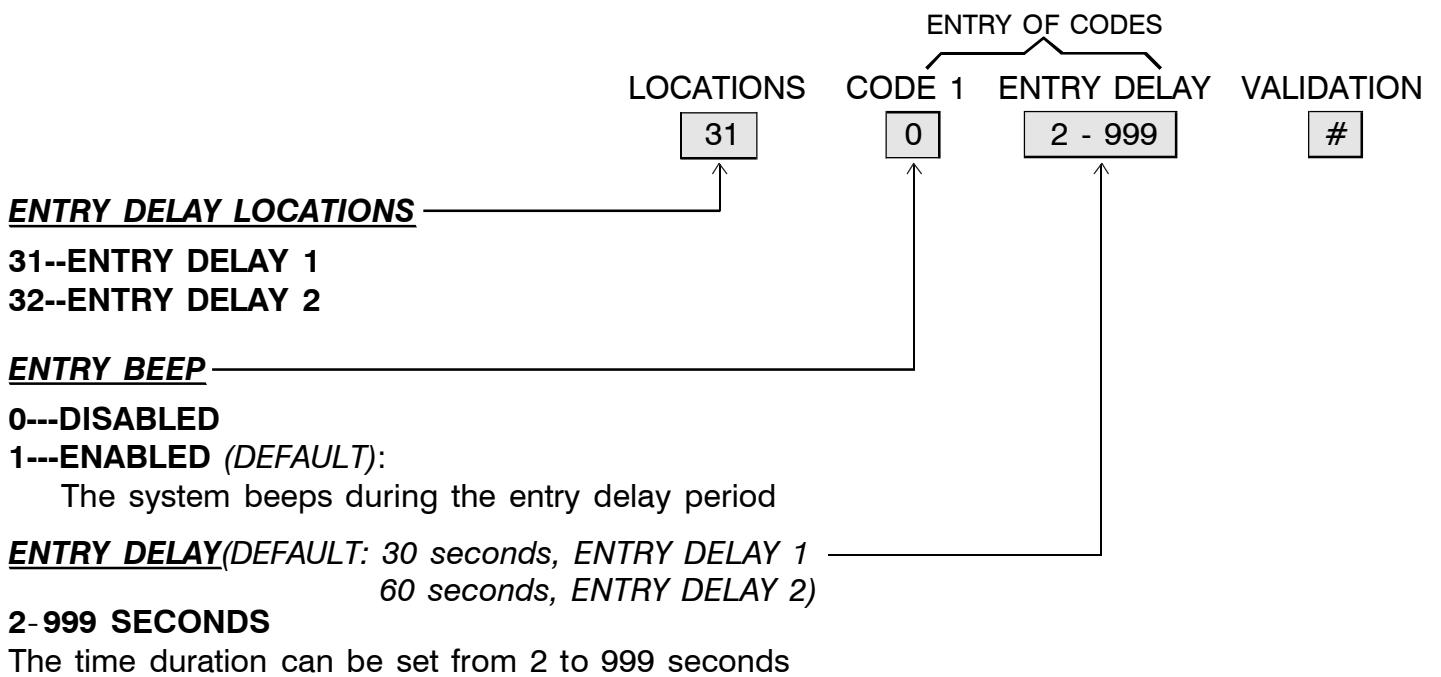

SETTING THE SIREN DURATION

(Location: 33)

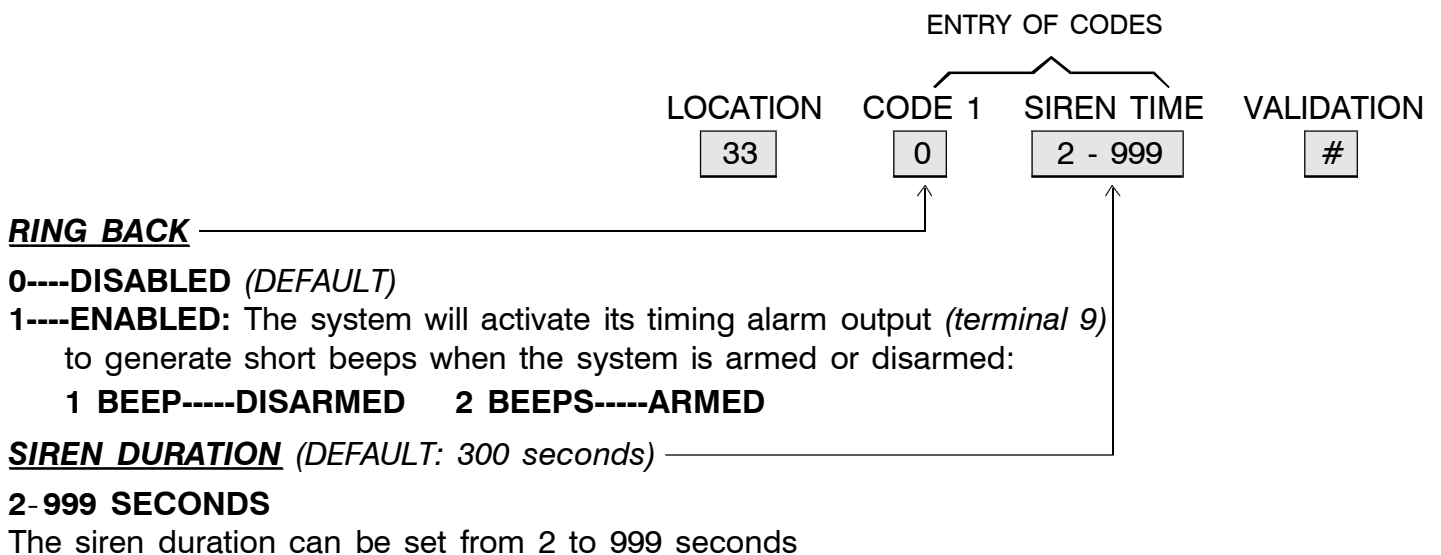

SELECTION OF FORCED TO ARM OR ARM PROHIBITED**(Location: 40)**

LOCATION	ENTRY OF CODE	VALIDATION
40	0	#

FORCED TO ARM - ARM PROHIBITED**0----FORCED TO ARM: (DEFAULT)**

Any zone that is violated will be isolated after the exit delay expired when the system is armed. The faulty zone(s) will be shown on the zone LED(s).

A **FORCED TO ARM** report will be sent if the communicator is enabled.

WARNING: The isolated zone is not protected.

1----ARM PROHIBITED:

Any zone that is faulty (open windows, malfunctioning sensor, etc.), the system will not arm. The owner will not be able to arm the system until the faulty zone is cleared or manually isolated.

5 beeps will be generated after the exit delay expired to indicate that the alarm system is not armed. The zone LED(s) will indicate the faulty zone(s). See **Arm Prohibited LED light** for more indication details.

An **ARM PROHIBITED** report will be sent if the communicator is enabled.

A faulty zone which is manually isolated after **arm prohibited** is considered as an isolated zone in normal operation. The system will be armed after the exit delay expired.

SETTING THE HANDOVER FUNCTION**(Location: 41)**

LOCATION	ENTRY OF CODE	VALIDATION
41	0	#

HANDOVER

0----DISABLED: (DEFAULT) The system is in normal operation. All the protection zones are having their functions according to the zone configuration settings.

1----ENABLED: In handover condition, any delay zone is triggered first, the instant zones (*Except the 24-hour zones*) will be disabled during the entry delay period. With this feature, the owner can set the motion sensors for interior protection with the instant zones and the main door protection with delay zone. The system will always give instant alarm if the person does not enter the house from the main door entrance.

TELEPHONE NUMBERS FOR COMMUNICATOR SENDING ALARM - STATUS REPORT (Location: 50-51)

LOCATIONS	TELEPHONE NUMBERS	VALIDATION
50	32 DIGIT MAX	#

COMMUNICATOR LOCATIONS

50----MASTER TELEPHONE: The master telephone number is the monitor station number to ring.

51----BACKUP TELEPHONE: The backup telephone number is intended as an alternate monitor station contact number for use when the master number fails to answer. Entering of the backup number is optional.

THE TELEPHONE NUMBERS

A telephone number of 32 digits maximum is allowed for each communicator location.

NOTE:

- The communicator is DISABLED in DEFAULT setup. Enable the communicator (*Location: 80*) and enter the telephone number are necessary to activate the function.
- The dialing sequence for the Master telephone and the Backup telephone is according to the setup on dialing attempts for communicator (*Location: 70*).
- The communicator has the priority to dial. After the communicator dialing is finished, the system will start to dial the telephone numbers in the auto-dialer.
- If backup telephone is not necessary, disable it by entering of the [Location Number], and then key-in the [#] without telephone number.
- After the line is connected, a status report or an alarm report will be sent to the monitor station in DTMF according to the communicator format stated in page 39.
- If the system is not connected to the monitor station, the communicator programming is not necessary.

TELEPHONE NUMBERS FOR AUTO-DIALER SENDING VOICE OR NUMERIC MESSAGE (Location: 60-63)



DIALER LOCATIONS

- 60----1st TELEPHONE NUMBER
- 61----2nd TELEPHONE NUMBER
- 62----3rd TELEPHONE NUMBER
- 63----4th TELEPHONE NUMBER

NUMERIC OR VOICE MESSAGE

0---NUMERIC MESSAGE: The numeric message is the secret code of your own or the code that represents some meanings for alarm reporting that you put after the telephone number. The system will send the numeric message to your pager when alarm occurs. If numeric message is selected, no voice message will be sent on that telephone number.

1---VOICE MESSAGE: The system will send the recorded message to the programmed telephone number when alarm occurs.

THE TELEPHONE NUMBERS

A telephone number of 32 digits maximum is allowed for each dialer telephone location.

NOTE:

- The dialer is ENABLED in DEFAULT setup. Simply enter telephone number(s) to activate the function.
- The dialing sequence is telephone 1, 2, 3, 4. The number of dialing attempts will repeat this sequence until the attempts are reached.
- After the line is connected, the dialer will send the voice message to the telephone(s), or the numeric codes to the pager(s).
- The numeric message is considered as part of the telephone number. It is necessary to limit the code length of the telephone number plus the numeric message to 32 digits maximum.
- No listen-in function is available, when the location is programmed for sending numeric message.
- If less than 4 telephones are required for alarm reporting, just delete those locations with its [Location Number] and key-in [#] without telephone number.

PUTTING PAUSE TO A TELEPHONE NUMBER

On programming of the telephone numbers for communicator and auto-dialer, dialing pause can be put into a telephone number during number entry. Maximum 5 pauses can be allowed for one telephone number and they can be put at any position of the number; beginning, ending and between digits are all possible.

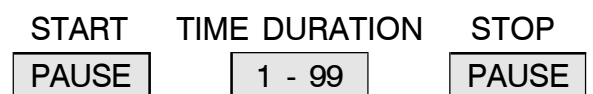

Press [**PAUSE**] key to start the pause time

The pause duration can be **1 to 99 seconds**

Press [**PAUSE**] key again to end the pause time

WHY PAUSE IS NECESSARY

Allowing pause in telephone number programming is very important in some applications. Otherwise, the communication between the alarm system and the receiving party is not possible. Such as dialing to an auto-pager station, or dialing out through an PABX extension line (*only for those PABX systems accept standard tone dialing telephones can be used*).

WHEN PAUSE IS REQUIRED

1) Dialing to an auto-pager station from the auto-dialer

When the system dials to an auto-pager station, and the line is through. The pager station will reply with a message, such as **Welcome to use ABC company auto-paging service...., please enter your personal code after the beep**. Usually this message lasts for 20 to 30 seconds. If the system sends the status report or the numeric data immediately after the line is through, before the end of the message, the data will be lost or the auto-pager station can not recognize the calling party and refuse to make a call.

To know the length of the replying message, you can dial to the auto-pager station and count the time while you are listening to the message. For example, the time that you have counted is 23 seconds which will be the pause time required. To allow tolerance, we suggest making a pause time of 25 seconds before sending the numeric message after the line is through.

The following is the programming example of sending a numeric message to an auto-pager station.

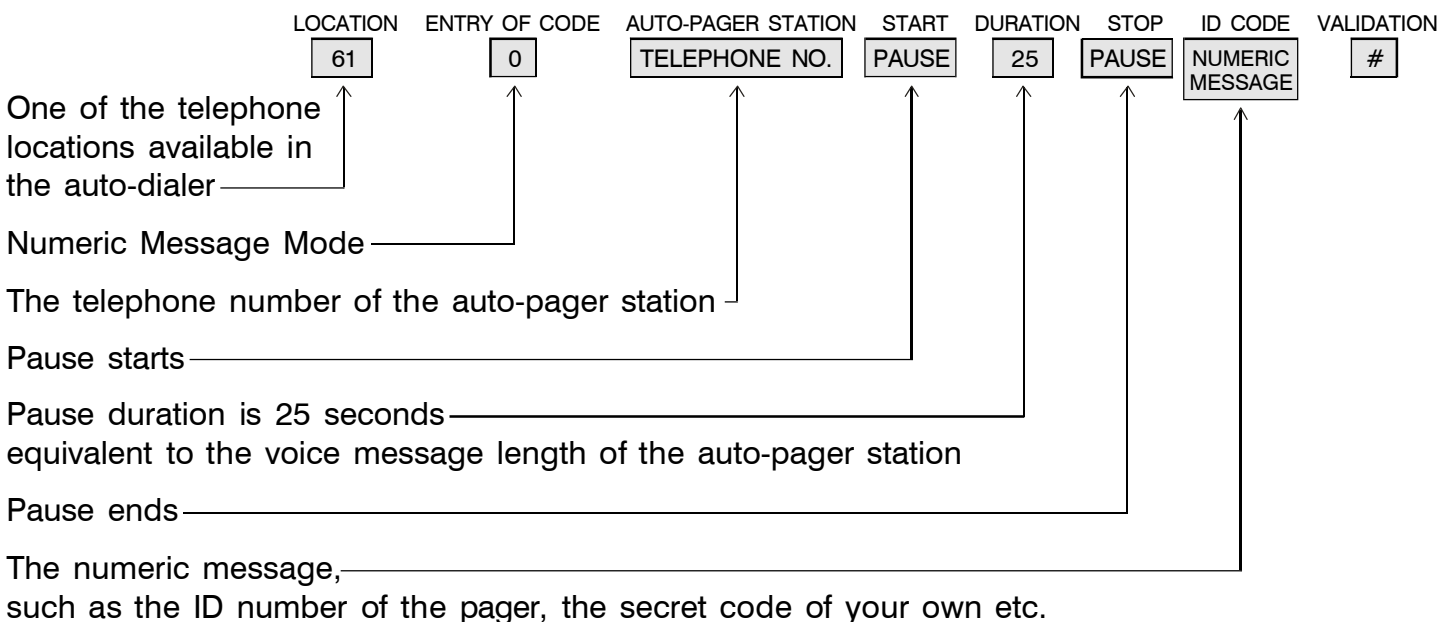

NOTE:

- The total number of digits of the telephone number and the numeric message is 32 digits maximum.
- Only the numeric message will be displayed on your pocket pager.

2) Sending an alarm report to your auto-pager from communicator

If your pocket pager has 20 digits or more space to receive data, with the pause function, you can request the system to send the alarm report to your pager as a back-up report while the system sends report to the monitor station.

The code of entries for the programming are as follows:

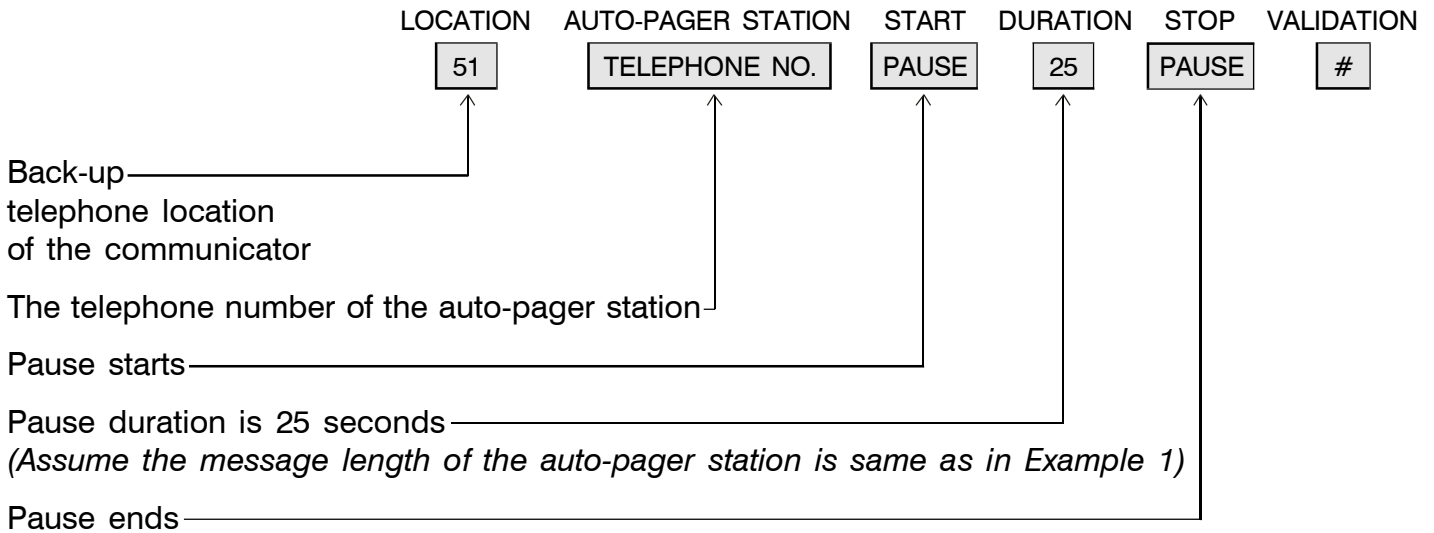

NOTE:

The display of the alarm report on your pager is according to the communicator alarm report format. See page 39 for details.

3) Sending voice message/alarm report via an PABX system

If your alarm system is connected to one of the extension lines of an PABX system, the communicator/dialer usually requires to dial a number first (*usually a "9" or "0"*) and waits around 1-2 seconds to pick up an external line before it can dial the telephone number for alarm reporting.

The code of entries for the system dialing via an PABX system are as follows:

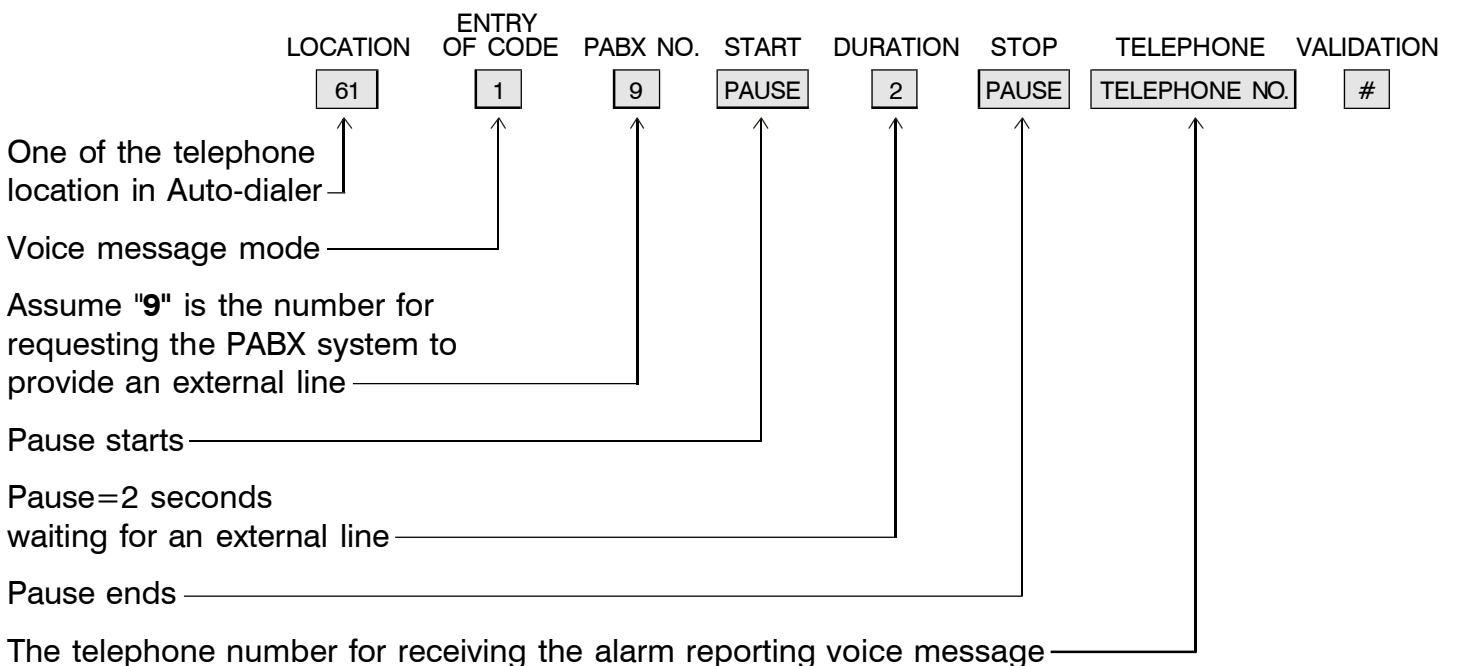

NOTE:

- 1) Connecting the dialer/communicator to an PABX system is usually not recommended, unless direct line is not available.
- 2) Only the PABX system that accepts standard tone dialing telephone as extension unit can be used.

DIALING ATTEMPTS FOR COMMUNICATOR

(Location: 70)

LOCATION ENTRY OF CODE VALIDATION
70 1 #

DIALING ATTEMPTS (DEFAULT: 4)

1 to 8 dialing attempts are possible

NOTE:

The system will make the number of dialing attempts to the master telephone number as programmed. Where the backup telephone number has been enabled the dialing attempts are split into the following sequence:

TELEPHONE NUMBER	2 ATTEMPTS	3 ATTEMPTS	4 ATTEMPTS	5 ATTEMPTS	6 ATTEMPTS	7 ATTEMPTS	8 ATTEMPTS
MASTER TELEPHONE	1,2	1,2	1,2	1,2,5	1,2,5,6	1,2,5,6	1,2,5,6
BACKUP TELEPHONE	----	3	3,4	3,4	3,4	3,4,7	3,4,7,8

- * Minimum dialing attempts of 3 are required if backup number is enabled
- * The interval for dialing attempt for different telephone number is 5 seconds while for the same telephone number is 60 seconds

DIALING ATTEMPTS FOR AUTO-DIALER

(Location: 71)

LOCATION ENTRY OF CODE VALIDATION
71 1 #

DIALING ATTEMPTS (DEFAULT: 4)

1 to 8 dialing attempts are possible

NOTE:

The dialing sequence is telephone 1,2,3,4. The number of dialing attempts will repeat this sequence until the attempts are reached.

- * The interval for dialing attempt for different telephone number is 5 seconds while for the same telephone number is 60 seconds

MESSAGE REPEATS**(Location: 72)**

LOCATION	ENTRY OF CODE	VALIDATION
72	1	#

MESSAGE REPEATS (DEFAULT: 4) —————
 1 to 8 message repeats are possible

NOTE:

After dialing and the line is through, the dialer pauses for 5 seconds and then transmits the recorded message. Every time the message finished, the dialer waits 3 seconds for the called party to acknowledge (*the acknowledgement signal is DTMF 1, press the 1 button on the telephone which is a tone dialing telephone*). Without an acknowledgement, the message will be repeated until the maximum number of message repeats are reached. The dialer will call the remaining numbers and will then retry the number(s) that did not acknowledge repeatedly until the maximum number of dialing attempts are reached.

SELECTION OF BACKUP OR NON-BACKUP REPORTING**(Location: 73)**

LOCATION	ENTRY OF CODE	VALIDATION
73	0	#

REPORTING MODE —————

0----NON-BACKUP MODE (DEFAULT)

1----BACKUP MODE

NOTE:

- The selected reporting mode for the system governs both the communicator and the auto-dialer sections. However, the acknowledgement required by the two sections are separated and independent.
- **NON-BACKUP REPORTING MODE**
 - a) On non-backup reporting mode, the COMMUNICATOR must receives an acknowledgement signal *DTMF 1* each from the master monitor station and the backup monitor station before the current event is considered to be reported and closed.
 For the application requires the alarm report sending to both the master monitor station and the backup monitor station, the selection of non-backup reporting mode is required.
 - b) On non-backup reporting mode, the DIALER must receives an acknowledgement signal *DTMF 1* from each telephone in the group of 4 before the current event is considered to be reported and closed.
- **BACKUP REPORTING MODE**
 - a) On backup reporting mode, the COMMUNICATOR receives an acknowledgement signal *DTMF 1* from the master monitor station is sufficient to consider the current event closed and call off the communicator session. The backup number there (*the 2nd monitor station*) is for backup purpose only in the case that the master number is out of order.
 - b) On backup reporting mode, the DIALER receives an acknowledgement signal *DTMF 1* from a SINGLE telephone in a group of 4 is sufficient to consider the current event closed and call off the dialer session. The remaining 3 telephones are there for backup purpose only.

THE LISTEN-IN FUNCTION ENABLE AND DURATION PROGRAMMING (Location: 74)

LOCATION	ENTRY OF CODE	VALIDATION
74	0	#

LISTEN-IN FUNCTIONS / DURATION**0---DISABLED****1-99---SECONDS (DEFAULT: 60 seconds):** 1 to 99 seconds, listen-in duration**NOTE:**

The listen-in function is available only on the auto-dialer section. At the end of the recorded voice message after a short beep, the dialer waits 3 seconds for the called party to acknowledge (**DTMF 1**). Upon receipt of the acknowledgement signal, the dialer removes the presently contacted telephone from its task list for the current event. This is the response of the system for listen-in function **DISABLED**. If the listen-in function is permitted, the dialer enables the listen-in for a pre-programmed period of time after acknowledgement.

At the end of the listen-in period, a short beep sounds. If **[1]** is keyed by the called party within 10 seconds, a new listen-in period begins. Without keying **[1]** the dialer will go **on hook** after 10 seconds. The listen-in period may be prolonged as many times as necessary or terminated by keying **[9]** after the short beep.

ARM-DISARM REPORT**(Location: 76)**

LOCATION	ENTRY OF CODE	VALIDATION
76	0	#

ARM-DISARM REPORT

0----DISABLED (DEFAULT)

1----ENABLED

NOTE:

- 1) On report enabled condition, the system will send an arming or disarming report to the monitor station each time when it is armed or disarmed.
- 2) Most of the alarm systems for office are disarmed at the morning and are armed at the evening; and those alarm systems for home are just opposite. If all the systems are sending the arm-disarm reports to the monitor station at the same time, there may not be enough telephone lines at the station to handle all the incoming reports.
Please consult your monitor station and have their permission first before enabling this function to prevent signal jammed.
- 3) No matter the selection is **DISABLED** or **ENABLED**. The system will always send Status report on **ARM PROHIBITED** or **FORCED TO ARM** condition after the exit delay expired if any protection zone is abnormal.

SELECTION OF DIALING COMBINATION**(Location: 80)**

LOCATION	ENTRY OF CODE	VALIDATION
80	0	#

THE DIALING COMBINATIONS

0----COMMUNICATOR AND DIALER OFF

1----COMMUNICATOR AND DIALER ON

2----COMMUNICATOR OFF, DIALER ON (DEFAULT)

3----COMMUNICATOR ON, DIALER OFF

NOTE:

- 1) Select **Communicator and Dialer OFF** for the system that is not connected to any monitor station or telephone for alarm reporting.
- 2) Select **Communicator and Dialer ON** for the system that is connected to both monitor station and telephones for alarm reporting.
The communicator has the priority to dial. After the communicator dialing is finished, the system will start to dial the telephone numbers for the dialer.
- 3) Select **Communicator OFF, Dialer ON** for the system that is only connected to telephones for alarm reporting with voice or numeric message.
- 4) Select **Communicator ON, Dialer OFF** for the system that is only connected to monitor station.

SELECTION OF DIALING MODE FOR CALLING THE TELEPHONE CENTRAL OFFICE (Location: 81)

LOCATION	ENTRY OF CODE	VALIDATION
81	0	#

DIALING MODES

0----STANDARD DTMF (DEFAULT)

1----PULSE, 33.3/66.6 10PPS

2----PULSE, 33.3/66.6 20PPS

3----PULSE, 40/60 10PPS

NOTE:

- 1) The dialing mode selected is for both the communicator and the dialer sections.
- 2) Select the right dialing mode to match the local telephone network system for the communication.
- 3) If pulse dialing mode is selected, the communicator dials the telephone number in pulse mode to make contact with the monitor station. After the line is through, the communicator still sends the alarm report to the monitor station in DTMF signal.
- 4) The system can only accept DTMF signal for remote arm/disarm control and making acknowledgement. Some of the feature that requires DTMF signal will be lost in the pulse telephone system.

NUMBERING BEEP TONES FOR CONTROL PANEL IDENTIFICATION (Location: 82)

LOCATION	ENTRY OF CODE	VALIDATION
82	0	#

IDENTIFICATION BEEP TONES

0----DISABLED (DEFAULT): The system is using the voice chip for alarm reporting.

1----CONTINUOUS 1-BEEP TONES, NO VOICE MESSAGE

2----CONTINUOUS 2-BEEP TONES, NO VOICE MESSAGE

3----CONTINUOUS 3-BEEP TONES, NO VOICE MESSAGE

NOTE:

- 1) The purpose of the numbering beep tones is designed to replace the voice message in those low cost version panels which have no voice chip to store the voice message to identify the alarm system.
- 2) It is always advised to disable the numbering function for those panels equipped with voice chip, unless, the numbering beep tones are considered to be more suitable for a specific application. Once the beep tone function is enabled, it will replace the voice message for alarm reporting.
- 3) The owner can use the number of beeps to identify the alarm system located if he has more than one alarm systems in his installations, such as has alarm systems at office, home and holiday house etc.

- 4) Alarm reporting with numbering beep tones is that, after the line is through, the dialer pause for 5 seconds and then transmits the numbering beep tones for 20 seconds. Every time the 20 seconds beep tones finished, the dialer waits 3 seconds for the called party to acknowledge (*the acknowledgement signal is DTMF 1*). Without an acknowledgement, the 20 seconds beep tones will repeat as the programmed number of message repeats (*at location 72, 1 to 8 message repeats are possible*). The dialer will call the remaining telephone numbers and will retry the number(s) that did not acknowledge repeatedly until the maximum number of dialing attempts are reached.

NUMBER OF RINGS TO PICK-UP TELEPHONE LINE ON REMOTE ACCESS (Location: 83)

LOCATION	ENTRY OF CODE	VALIDATION
83	0	#

NUMBER OF RINGS TO PICK-UP TELEPHONE LINE

0-----DISABLED: Remote access is not allowed.

1-99---RINGS (DEFAULT: 16): 1 to 99 number of rings are possible

NOTE:

- 1) The system has been designed to allow the owner to telephone the system remotely to check its arm-disarm status, to make arm-disarm control or to request the communicator for a current status report sending to the monitor station or to the owner's pocket pager.
- 2) In most cases that the telephone number of the system connected is the home telephone number of the owner. To set appropriate number of rings to pick-up the line is important to those systems using the home telephone line. The system will always pick-up the line before you pick-up the phone in daily use if you set too less number of rings. For the setting of too many number of rings, the owner has to wait a long time for the system to pick-up the line to accept remote access.
- 3) A system that has dedicated telephone line for communication can be set with 2 to 3 rings to pick-up the line to speed up the access.
- 4) Some of the telephone networks do not accept too many number of rings and cut the line before the number of rings are reached. If that be the case, immediately hang up and call the system back. The system remembers the number of rings for 45 seconds after a call attempt has been terminated. It will continue to count rings through repeated attempts until the number of rings have occurred.
- 5) Please see page 11, D.T. JUMPER setting for more information.

PERIODIC REPORT**(Location: 84)**

LOCATION	ENTRY OF CODE	VALIDATION
84	0	#

PERIODIC REPORT**0----DISABLED (DEFAULT)****1----GIVES STATUS REPORT EVERY 12 HOURS****2----GIVES STATUS REPORT EVERY 24 HOURS****3----GIVES STATUS REPORT EVERY 7 DAYS****NOTE:**

- 1) To enable the periodic report is optional.
- 2) Periodic report may not be necessary if the system is for daily use.
- 3) If the alarm system is left in a place for a period of time without arm-disarm control. Such as the owner is on holiday for few weeks, to make sure it works properly during that period, the owner can set the system to give periodic report.
- 4) The period report shows the current status of the system when the report is sent. The report is based on the communicator format shown on page 39, which can be sent to the monitor station and / or to the owner's pocket pager.
- 5) The periodic report counting starts at the time when the system is powered up.

POWER-UP DELAY**(Location: 85)**

LOCATION	ENTRY OF CODE	VALIDATION
85	0	#

POWER-UP DELAY**0----DISABLED (DEFAULT)****1----ENABLED****NOTE:**

- 1) The purpose of power-up delay is to give a period of time for the system to stabilize and to charge up the backup battery after power-up at the first time, or power-up after a long time of AC power failure and the backup battery is completely exhausted.
- 2) The power-up delay is 5 minutes. The system suppresses all the alarm outputs including the communicator and the dialer.
- 3) During the power-up delay period, the **AC POWER** and the **BATTERY** LED lights are flashing alternatively.
- 4) The system will send a status report to the monitor station 5 minutes after power up if the communicator is enabled.

PERIODIC BATTERY TEST**(Location: 86)**

LOCATION	ENTRY OF CODE	VALIDATION
86	0	#

PERIODIC BATTERY TEST**0----DISABLED (DEFAULT)****1----DAILY-24 HOURS****2----WEEKLY-7 DAYS****NOTE:**

- 1) When PERIODIC battery testing is selected, the system will dynamically test the backup battery every 24 hours or every 7 days. The time counting starts at the system power-up.
- 2) Every time after the testing, the system shows the battery status on the control console. Under some certain circumstances, it also sends a status report to the monitor station:
 - a) The battery is LOW
 - b) The battery resumes normal but it was LOW in the last testing.
 There is no status report sending to the monitor station if the battery is normal and it was normal as well in the last testing.
- 3) The system will automatically stop the battery testing in AC power failure condition, or, when the system is in alarm.

DIAL-TONE AND TELEPHONE LINE FAULT DETECTS**(Location: 87)**

LOCATION	ENTRY OF CODE	VALIDATION
87	0	#

DIAL-TONE AND TELEPHONE LINE FAULT DETECTS**0----DISABLED****1----ENABLED (DEFAULT)****NOTE:**

- A) Under the **DISABLED** condition, the system has the following manners to the telephone line:
 - 1) The communicator or the dialer makes dialing right away 4 seconds after getting the line.
 - 2) No telephone line fault detect function at system arm-disarm control.
- B) Under the **ENABLED** condition, the system has the following manners to the telephone line:
 - 1) The communicator or the dialer waits for the dial-tone and starts dialing if uninterrupted tone is detected for 4 seconds. If 6 seconds elapse with no dial tone, the communicator or the dialer disengages the line, waits 5 seconds and tries again. If another 6 seconds go by without dial tone, dialing starts anyway.
 - 2) Telephone line fault detect is performed every time at system arm-disarm control. The line is considered to be normal if uninterrupted dial-tone is detected for 4 seconds. The following indications will be given if the line is faulty:
 - a) Continuous 5 beep tones
 - b) The **DIALING** LED flashing

C) Please see page 11, D.T. JUMPER setting for more information.

To stop the line fault warning beep tones:

- Check the telephone line and its plug and socket, make sure the line is firmly connected. Try to make system arm-disarm control again to perform a new line fault test. If the line resumes normal, the beep tones will stop and the **DIALING** LED will revert to standby state.
- If the line is faulty due to the telephone network, the only way to stop the warning beep tones is to set the system on **DISABLE** state by programming.

PUTTING THE HABITUAL ISOLATION ZONES IN MEMORY FOR "HOME" MODE OPERATION (Location: HOME)

LOCATION	ENTRY OF CODE	VALIDATION
[HOME]	[1 TO 8]	[#]

ZONES PUTTING INTO MEMORY FOR ISOLATION

1-8---(DEFAULT: NIL): Key-in the zone numbers (zone 1 - zone 8) for isolation

NOTE:

- Entering the zone number(s) required to be isolated one by one into the memory. Continuous entry is possible.

Example: The key-in procedures of putting the zones 1,2 and 4 into memory for isolation for home operation are as follows:

PRESS [HOME] [1] [2] [4] [#]

WARNING: Making isolation to the 24 hour zone is not recommended. An isolated zone is not protected.

- Putting the habitual isolation zones in memory is convenient for the owner to set the system for **HOME** mode operation instantly. The owner does not require to set the zones one by one every time to make them isolated. With the habitual isolation zones stored in memory, the owner simply key-in the [User Code], then press the [HOME] and [#] keys to make the system in home operation with the required zones isolated.

RECORD THE VOICE MESSAGE FOR REPORTING ALARMS (Location: RECORD)

LOCATION	VALIDATION
[RECORD]	[#]

HA-982S

The control console of the HA-982S is equipped with the [RECORD] key and the microphone on the panel.

To make recording, press the [RECORD] key followed immediately by the [#] key. The recording LED light will be ON indicating the beginning of the recording time and it will hold for 20 seconds until the end of the recording time.

HA-982R**BUTTON ON P.C.B. FOR RECORDING**

RECORD

The [RECORD] key and the microphone of the HA-982R are equipped on the main printed circuit board inside the metal cabinet. The owner has to open the cabinet for making recording. A RECORD LED, a RECORD button and a microphone can be found near the top right hand side of the circuit board.

Only press the [RECORD] button once is required to begin the time for message recording. The RECORD LED will be ON and it will hold for 20 seconds until the end of the recording time.

NOTE: The cabinet tamper switch is disabled when the system is in **PROGRAM** mode.

RECORDING THE VOICE MESSAGE

- 1) The message usually put into an alarm system is an identification message for alarm reporting. Please write down your message on a paper and try to read it aloud & clearly with a steady speed and keep the time in 20 seconds. Practice the message until you can read it within the time limit.
- 2) When the RECORD LED is ON steadily (*recording starts*), read the 20 seconds message aloud, with your face about 30 cm (1 ft.) from the microphone. The LED light will stop automatically when 20 seconds expired and your message is stored.
- 3) Recording can be repeated as many times as you like until the message is in your satisfaction. The newly recorded message replaces the old one.

SETTING THE SYSTEM WITH DEFAULT VALUES**(Location: 02)**

WARNING: When set the system with the default programme, except the voice message and the Master Code, all the values programmed previously will be cleared and replaced by the default values that shown on the **Default Data Chart** on page 13.

Key-in the programming location followed immediately with the [#] key, the system starts to down load the default values into its memory, which takes around 2 seconds. After that, the default values on the **default Data Chart** are entered.

LOCATION	VALIDATION
02	#

EXIT THE PROGRAMMING MODE

After programming is finished, the system has to be set to exit the programming mode and back to operation mode. Exit the programming mode can be done at anytime by pressing the [*] key twice.

VALIDATION
* *

PROGRAM SUMMARY CHART

LOCATION NO.	DESCRIPTION OF PARAMETERS	ENTRY LIMITS AND CODE OPTIONS	PROGRAMMING FORMAT	FACTORY DEFAULT	YOUR PROGRAM RECORD
01	Master Code	2-5 DIGITS	01 MASTER CODE #	NONE	
02	Factory default values	WARNING: With the entry of this location, all the values previously programmed will be cleared and replaced by factory default values except the voice message and the master code.		SEE THE DEFAULT VALUES IN THIS COLUMN	
10	Client code	4 Digits	10 CLIENT CODE #	0000	
11	User code 1	2-5 Digits	11 USER CODE 1 #	NONE	
12	User code 2		12 USER CODE 2 #	NONE	
13	User code 3		13 USER CODE 3 #	NONE	
14	User code 4		14 USER CODE 4 #	NONE	
15	User code 5		15 USER CODE 5 #	NONE	
16	User code 6		16 USER CODE 6 #	NONE	
17	User code 7		17 USER CODE 7 #	NONE	
18	User code 8		18 USER CODE 8 #	NONE	
21	Configuration of zone 1	CODE 1: 0 or 1 0---Single Trigger 1---Multiple Trigger CODE 2: 0,1,2,3 or 4 0---Instant 1---Entry Delay 1 2---Entry Delay 2 3---24-Hour Instant 4---24-Hour Silent Panic CODE 3: 0,1,2 or 3 0---25mS 1---250mS 2---500mS 3---750mS	21 CODE 1 CODE 2 CODE 3 #	CODE 1=1 CODE 2=1 CODE 3=2	
22	Configuration of zone 2		22 CODE 1 CODE 2 CODE 3 #	CODE 1=1 CODE 2=1 CODE 3=2	
23	Configuration of zone 3		23 CODE 1 CODE 2 CODE 3 #	CODE 1=1 CODE 2=0 CODE 3=2	
24	Configuration of zone 4		24 CODE 1 CODE 2 CODE 3 #	CODE 1=1 CODE 2=0 CODE 3=2	
25	Configuration of zone 5		25 CODE 1 CODE 2 CODE 3 #	CODE 1=1 CODE 2=0 CODE 3=2	
26	Configuration of zone 6		26 CODE 1 CODE 2 CODE 3 #	CODE 1=1 CODE 2=0 CODE 3=2	
27	Configuration of zone 7		27 CODE 1 CODE 2 CODE 3 #	CODE 1=1 CODE 2=3 CODE 3=2	
28	Configuration of zone 8		28 CODE 1 CODE 2 CODE 3 #	CODE 1=1 CODE 2=3 CODE 3=2	
30	Exit delay and exit beep	CODE: 0 or 1 0---Exit Beep Disabled 1---Exit Beep Enabled EXIT DELAY: 2-999 Seconds	30 CODE SECONDS #	CODE=1 60 Seconds	

LOCATION NO.	DESCRIPTION OF PARAMETERS	ENTRY LIMITS AND CODE OPTIONS	PROGRAMMING FORMAT	FACTORY DEFAULT	YOUR PROGRAM RECORD
31	Entry delay 1 and entry beep	CODE: 0 or 1 0---Entry Beep Disabled 1---Entry Beep Enabled ENTRY DELAY 1: 2-999 Seconds	[31] [CODE] [SECONDS] [#]	CODE=1 30 Seconds	
32	Entry delay 2 and entry beep	CODE: 0 or 1 0---Entry Beep Disabled 1---Entry Beep Enabled ENTRY DELAY 2: 2-999 Seconds	[32] [CODE] [SECONDS] [#]	CODE=1 60 Seconds	
33	Siren duration and ring back	CODE: 0 or 1 0---Ring Back Disabled 1---Ring Back Enabled SIREN DURATION: 2-999 Seconds	[33] [CODE] [SECONDS] [#]	CODE=0 300 Seconds	
40	Forced to arm or arm prohibited	CODE: 0 or 1 0--Forced to Arm Mode 1--Arm Prohibited Mode	[40] [CODE] [#]	0 (Forced to arm)	
41	Handover or non-handover mode	CODE: 0 or 1 0--Non-handover Mode 1--Handover Mode	[41] [CODE] [#]	0 (Non-handover)	
50	Master telephone number for communicator	32 Digits	[50] [NUMBER] [#]	NONE	
51	Backup telephone number for communicator		[51] [NUMBER] [#]	NONE	
60	1st telephone number for dialer	CODE: 0 or 1 0---Numeric Message 1---Voice Message TELEPHONE NUMBER: 32 Digits	[60] [CODE] [NUMBER] [#]	NONE	
61	2nd telephone number for dialer		[61] [CODE] [NUMBER] [#]	NONE	
62	3rd telephone number for dialer		[62] [CODE] [NUMBER] [#]	NONE	
63	4th telephone number for dialer		[63] [CODE] [NUMBER] [#]	NONE	
	Pause time for inserting between digits, putting before and after the number in communicator and dialer programming	1-99 Seconds	[PAUSE] [SECONDS] [PAUSE]	NONE	
70	Number of dialing attempts for communicator	1-8 Attempts	[70] [NUMBER] [#]	4	
71	Number of dialing attempts for dialer	1-8 Attempts	[71] [NUMBER] [#]	4	
72	Number of message repeats	1-8 Repeats	[72] [NUMBER] [#]	4	
73	Backup or non-backup reporting	CODE: 0 or 1 0---Non-backup 1---Backup	[73] [CODE] [#]	0 (Non-backup)	

LOCATION NO.	DESCRIPTION OF PARAMETERS	ENTRY LIMITS AND CODE OPTIONS	PROGRAMMING FORMAT	FACTORY DEFAULT	YOUR PROGRAM RECORD
74	Listen-in duration	1-99 Seconds 0---Listen-in Disabled	74 SECONDS #	60 Seconds	
76	Arm-disarm reports	CODE: 0 or 1 0---Disabled 1---Enabled	76 CODE #	0 (Disabled)	
80	Dialing combination for communicator and dialer	CODE: 0, 1, 2 or 3 0---Communicator & Dialer OFF 1---Communicator & Dialer ON 2---Communicator OFF, Dialer ON 3---Communicator ON, Dialer OFF	80 CODE #	2 (Communicator OFF, Dialer ON)	
81	Dialing medium	CODE: 0, 1, 2 or 3 0---Standard DTMF 1---33.3/66.6 10pps. 2---33.3/66.6 20pps. 3---40/60 10pps.	81 CODE #	0 (DTMF)	
82	Using beep tones to replace the voice message	CODE: 0, 1, 2 or 3 0---Voice Message 1---1 Beep Continuous 2---2 Beep Continuous 3---3 Beep Continuous	82 CODE #	0 (Voice Message)	
83	Number of rings to pick-up telephonenumber	1-99 Rings 0---Call in Disabled	83 NUMBER #	16	
84	Periodic report	CODE: 0, 1, 2 or 3 0---No Report Function 1---Sends Status Report Every 12 Hours 2---Sends Status Report Every 24 Hours 3---Sends Status Report Every 7 Days	84 CODE #	0 (Disabled)	
85	Power-up delay	CODE: 0 or 1 0---Disabled 1---Enabled	85 CODE #	0 (Disabled)	
86	Periodic battery testing	CODE: 0, 1 or 2 0---Periodic Testing Disabled 1---Test Every 24 Hours 2---Test Every 7 Days	86 CODE #	0 (Disabled)	
87	Line fault and dial tone detects	CODE: 0 or 1 0---Disabled 1---Enabled	87 CODE #	1 (Enabled)	
HOME	Isolation zones in memory	ZONES: 1,2,3,4,5,6,7 and 8	HOME ZONES #	NONE	
RECORD	Recording the alarm reporting message	20 Seconds Fixed	RECORD #	NONE	

REMARKS:**● Entering to programming mode**

Whenever programming is required, it is necessary to set the system into programming mode first by entering the master code and validate by pushing the [*] key twice:

MASTER CODE [*] [*]

● Leaving the programming mode

Whenever the programming is finished, simply push the [*] key twice to leave the programming mode:

[*] [*]

COMMUNICATOR ALARM-STATUS REPORT FORMAT

The communicator of the HA-982 is using the most popular medium, DTMF, in data communication. Which allows the system owner to set up a private monitor station if he has several systems installed; or the installer to set up a proprietary monitor station for the small to medium size community for his clients with a personal computer through a Standard Voice Modem.

The owner or the installer can prepare an alarm monitoring software on his preference by himself according to the stated alarm-status report format with the source codes provided; or use the AEI standard software **ALARM-MONITOR** for the station.

The communicator sends the report 5 seconds (*additional time can be made via pause programming if necessary*) after the line is connected to the monitor station. The report can also be sent directly to a pocket auto-pager (*minimum 20-digit display required*) with the pager's phone number and the appropriate pause time programmed.

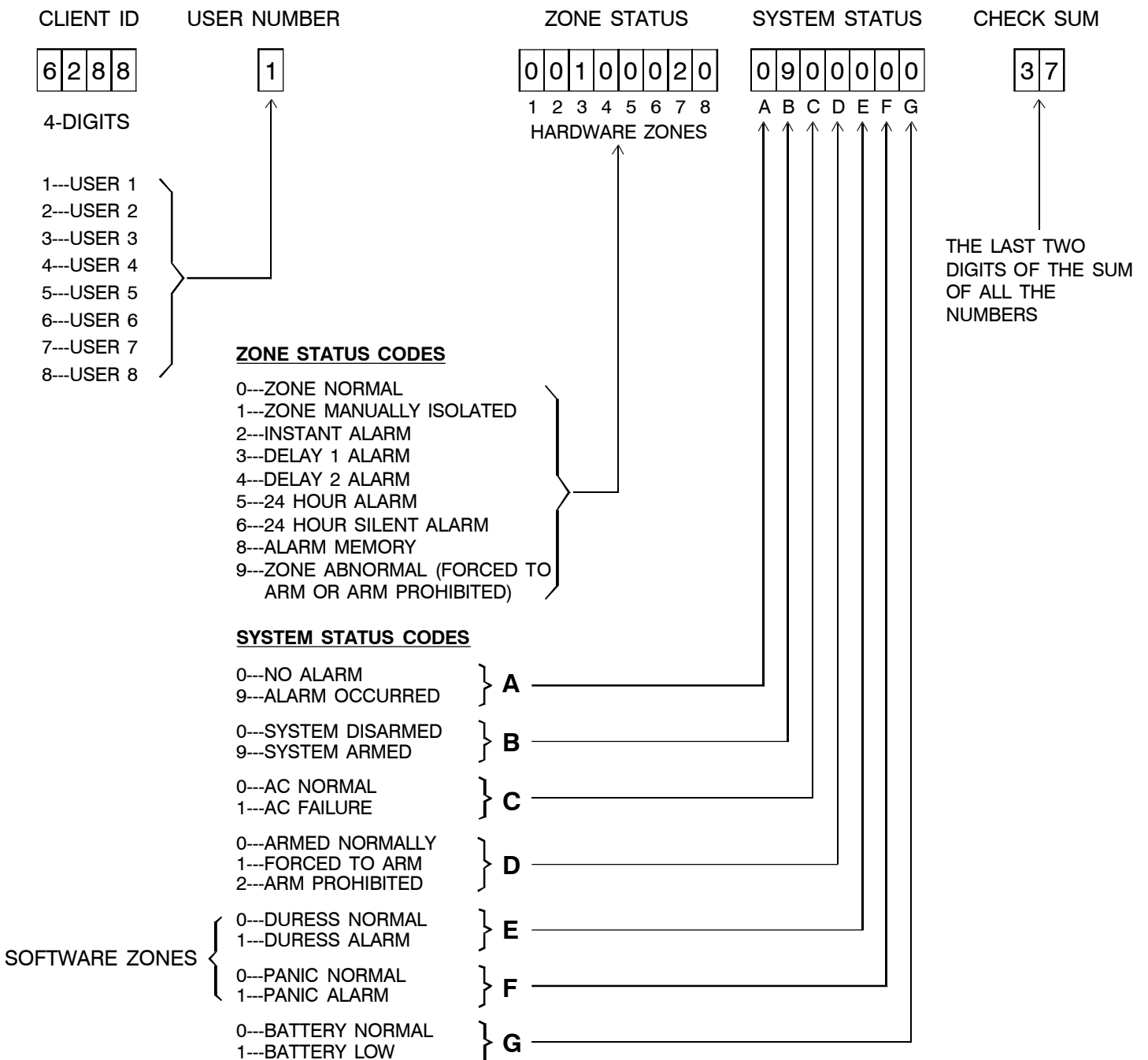

DESCRIPTION OF THE REPORT PARAMETERS (THE SOURCE CODES)

- **CLIENT ID**

The client ID is the client's identification number, which must be a 4-digit number.

- **USER NUMBER**

8 user ID numbers are available for operating of the alarm system. The latest user who operates the system will be recorded in the report.

NOTE: Utilizing of the key switch to arm-disarm the system is always considered as user 1 in the report.

- **ZONE STATUS CODES**

The system shows the status of each protection zone with the status code in the report for all 8 zones.

0---The zone is normal.

1---The zone is MANUALLY ISOLATED by the user.

2---Alarm is occurred, an INSTANT ALARM zone.

3---Alarm is occurred, an ENTRY DELAY 1 alarm zone.

4---Alarm is occurred, an ENTRY DELAY 2 alarm zone.

5---Alarm is occurred, a 24-HOUR INSTANT alarm zone.

6---Alarm is occurred, a 24-HOUR SILENT PANIC alarm zone.

8---The zone is in ALARM MEMORY, alarm was occurred.

9---The zone is ABNORMAL, the system is forced to arm or arm prohibited.

- **SYSTEM STATUS CODES**

The 7 digit system status code represents 7 events in the system. The alarm report always reflects the current status of the system, and that the report made by call for status from a telephone always reflects the status of the latest events of the system.

A: 0---NO ALARM

9---ALARM OCCURRED: Alarm occurred at any hardware zone or software zone. TAKING ACTION IS REQUIRED

B: 0---SYSTEM DISARMED: Only the 24-hour zones and the software zones are effective.

9---SYSTEM ARMED: All the hardware and software zones are effective if the protection zones are normal.

C: 0---AC NORMAL

1---AC FAILURE: AC power is not supplied, system is using battery.

D: 0---ARMED NORMALLY: The system is armed normally, the protection zones are normal or the faulty zone(s) is manually isolated.

1---FORCED TO ARM: The system is forced to arm due to faulty zone(s) existing. Checking the **zone status** report for the faulty zone(s) which is indicated on its location with the zone status code, number **9**, zone abnormal.

2---ARM PROHIBITED: The system is not armed after the exit delay expired due to faulty zone(s) existing. Check the **zone status** report for the faulty zone(s) which is indicated on its location with the zone status code, number **9**, zone abnormal.

E: 0---DURESS NORMAL

1---DURESS ALARM: The duress code is keyed-in. The system activates the communicator and the auto-dialer for alarm reporting but gives no local alarm. This is a software zone.

F: 0----PANIC NORMAL

1----PANIC ALARM: The system is activated to give alarm by panic button (*press any two keys on the control console simultaneously for more than 3 seconds*). This is a software zone.

G: 0----BATTERY NORMAL

1----BATTERY LOW: The back-up battery is low. Call the service department.

● **CHECK SUM**

The check sum is a number of the last 2 digits of the sum of all the numbers (*total 20 digits*) in the report added together. It is a tool for the monitor station to check whether all the data in the report are received correctly.

THE ACKNOWLEDGEMENT SIGNAL FOR COMMUNICATOR

At the end of the 22 digits (*including the check sum*) of the source codes in the alarm status report have been sent out, the communicator waits 3 seconds for the monitor station to acknowledge, the acknowledgement signal required is an DTMF **1**. Upon receipt of the acknowledgement signal, the communicator considers that the event is reported and closed. Without an acknowledgement, the communicator will retry the number(s) that did not acknowledge repeatedly until the maximum number of dialing attempts are reached.

INTERPRETTING THE REPORT - EXAMPLES

1. An Alarm Report

CLIENT	USER	ZONES	SYSTEM STATUS	CHECKSUM
6288	1	00109020	9901000	56
		1 2 3 4 5 6 7 8	A B C D E F G	

The report is from client number 6288. The system is armed by user 1, zones 1, 2, 4, 6 and 8 are normal, zone 3 is manually isolated, zone 5 is faulty, zone 7 which is in alarm is an instant alarm zone, action is required due to alarm occurred, system is in armed mode. AC is normal, the system is forced to arm due to faulty zone (*zone 5*) existing, duress zone is normal, panic zone is normal, battery is normal, and that the check sum is 56 which is correct.

2. A Duress Alarm Report

CLIENT	USER	ZONES	SYSTEM STATUS	CHECKSUM
9756	2	00000000	9000100	39
		1 2 3 4 5 6 7 8	A B C D E F G	

The report is from client number 9756, the system was disarmed by user 2, all protection zones are normal, alarm occurred and taking action is required, system is in disarmed mode. AC is normal, system is normal with no faulty zone. Duress zone is in alarm, panic zone is normal, battery is normal, and that the check sum is 39 which is correct.

3. A Report is Requested by Means of Call For Status

CLIENT	USER	ZONES	SYSTEM STATUS	CHECKSUM
8321	6	00000080	0000000	28
		1 2 3 4 5 6 7 8	A B C D E F G	

The report is from client 8321, the system was disarmed by user 6, all protection zones are normal except zone 7 is in alarm memory because alarm was occurred, no alarm is occurred, system is in disarmed mode. AC is normal, system is normal with no faulty zone, duress zone is normal, panic zone is normal, battery is normal, and that the check sum is 28 which is correct.

ALARM--SYSTEM STATUS--TESTING EVENTS REPORTING MEDIA SUMMARY CHART

REPORTING MEDIA <i>ALARM EVENTS</i>	LOCAL ALARM (SIREN/STROBE)	AUTO-DIALER	COMMUNICATOR
DELAY ZONES	✓	✓	✓
INSTANT ZONES	✓	✓	✓
24-HR INSTANT ZONES	✓	✓	✓
24-HR SILENT ZONES	—	✓	✓
PANIC	✓	✓	✓
DURESS	—	✓	✓
TAMPER SWITCH	✓	✓	✓
<i>SYSTEM STATUS EVENTS</i>			
FORCED TO ARM	—	—	✓
ARM PROHIBITED	—	—	✓
BATTERY LOW	—	—	✓
AC POWER FAILURE	—	—	✓
SYSTEM ARM-DISARM	—	—	✓
PERIODIC REPORT	—	—	✓
REQUESTING A STATUS REPORT	—	—	✓
<i>TESTING EVENTS</i>			
ALARM OUTPUT TESTING	✓	—	—
AUTO-DIALER TELEPHONE NO. TESTING	—	✓	—
COMMUNICATOR TELEPHONE NO. TESTING	—	—	✓

REMARK: Assume that all the program options for communicator and auto-dialer are enabled.

ACCESS THE SYSTEM REMOTELY

The HA-982 may have been set up to allow the owner to telephone the system (See *Program Location 83*) to determine of its present status or to request a detailed status report. Configured this way you can also turn the system arm or disarm remotely by telephone. The call can be made from any telephone capable of tone dialing, including DTMF capable mobile telephones.

For obvious security reasons the system only allows to use USER CODE 1 for remote arm-disarm control.

The system generates different answering beeps to response to the access from the remote telephone. The owner can key-in the appropriate command code for the specific task if required after the answering beep.

THE MEANING OF THE ANSWERING BEEPS

NO.	ANSWERING BEEPS	MEANINGS
1	1 beep	<ul style="list-style-type: none"> ● System is disarmed
2	2 beeps	<ul style="list-style-type: none"> ● System is armed
3	1 beep + 3 beeps	<ul style="list-style-type: none"> ● System is disarmed, but ● Alarm is occurred (due to the 24 hours or the software zones)
4	2 beeps + 3 beeps	<ul style="list-style-type: none"> ● System is armed, and ● Alarm is occurred
5	1 beep + 2 beeps	<ul style="list-style-type: none"> ● System is disarmed, but ● System is in alarm memory, at least one of the protection zones was in alarm
6	5 beeps	<ul style="list-style-type: none"> ● Unsuccessful code entry, try again
7	2 beeps + 5 beeps	<ul style="list-style-type: none"> ● Successful code entry but the function request is rejected due to system arm prohibited

THE COMMAND CODES FOR REMOTE ACCESS CONTROL

NO.	COMMAND CODES	MEANINGS
A	USER CODE 1 #	<ul style="list-style-type: none"> ● To arm the system if it is disarmed, or ● To disarm the system if it is armed
B	USER CODE 1 * 3 #	<ul style="list-style-type: none"> ● To clear the alarm memory and keep the system in disarmed mode
C	USER CODE 1 * 6 #	<ul style="list-style-type: none"> ● To clear the alarm memory and re-arm the system which is in alarm memory state
D	CLIENT CODE #	<ul style="list-style-type: none"> ● Requesting the system to send a report of its currently registered status to the monitor station or to an auto-pager ● The report will be sent 10 seconds after the command code is successfully entered, 2 beeps will be generated to confirm successful code entry

REMOTE ARM-DISARM THE SYSTEM BY TELEPHONE

1. Ring the number that the system is connected. In most cases that is the home telephone number of the owner.
2. After the pre-set number of rings (*programmed at location 83*) the system will answer the phone with the answering beep(s) to show its current status.
3. If the owner only wants to check on the STATUS of the alarm system, without making any change, simply hang up after the answering beep is heard.
4. If the owner wants to change the status of the system, now enter the appropriate command code using the telephone keypad. If a mistake is made then press the **#** key (*5 beeps will be heard*) and try again. If four incorrect attempts are made to enter the command code, the system will terminate the session and hang up.
5. The command code A can be entered for status change if the answering beep is No.1, 2, 3, or 4; and that the command code B or C can be entered for status change if the answering beep is No.5.

The following is a summary chart that shows the status changes after the command codes are entered:

ANSWERING BEEP NO.	CURRENT STATUS	COMMAND CODE ENTRY	STATUS AFTER COMMAND CODE IS ENTERED
1	System is disarmed	A	System will be armed
2	System is armed	A	System will be disarmed
3	System is disarmed and in alarm condition (<i>due to the 24 hour or the software zones</i>)	A	System will be disarmed, alarm will be reset and changed to alarm memory
4	System is armed and in alarm condition	A	
5	System is disarmed with alarm memory	B	System keeps in disarmed and the alarm memory will be cleared
		C	System will be armed and the alarm memory will be cleared

6. For example, if the system is in disarmed mode, it will be turned ON, **armed**, instantly and two beeps will be heard after the entry of command code A, **user code 1 #**. If the system is in armed mode, it will be turned OFF, **disarmed**, and one beep will be heard to announce that the system is disarmed.

NOTE: Selection of HOME or AWAY operation is not available on remote arm-disarm control. The system always arms itself at AWAY mode instantly when the command code is entered.

7. Hang up the telephone immediately to allow the communicator (*if it is enabled, see program Locations 76 and 80*) to ring the monitor station or the paging station as a result of armed or disarmed the system.

In case of ARM PROHIBITED or FORCED TO ARM occurred, the communicator will always ring the monitor station because it is a system problem.

CALL FOR A STATUS REPORT

The communicator of the alarm system may have been set up to allow the authorized person or the owner to call for a current status report. The procedure is similar to that of remote Arm-Disarm the System stated above.

1. Ring the number that the system is connected with an DTMF telephone.
2. After the pre-set number of rings, the system will answer the phone with the answering beep(s) to show its current status.
3. Enter the **CLIENT CODE** **#** , **the command code D**, using the telephone keypad. If the code entry is correct, two short beeps will be heard to confirm that the request will be done. Hang up the telephone immediately to allow the communicator to send the report. The report will be sent out to the monitor station or to the auto-pager 10 seconds after the confirmation beeps.
4. If a mistake is made in Client Code entry, press the **#** key (*5 beeps will be heard*) and try again. If four incorrect attempts are made, the system will terminate the session and hang up.

AC POWER FAILURE AND RESTORATION

The AC power LED indicates the current status, which is ON at AC normal, and it is FLASH at AC failure. The control console gives continuous 1 short beep/30 seconds during the AC power failure period.

- 1) AC power failure lasts for more than 15 minutes, an AC failure report will be sent if the communicator is enable.
- 2) When AC power is restored for 5 minutes, a restoration report will be sent.

DYNAMIC BATTERY TESTING

The system performs dynamic battery testing on the standby battery by interrupting AC power for 2 minutes and monitoring the battery under loaded condition.

- 1) Dynamic battery testing can be performed any time by manually keying-in the following command codes.

USER CODE * 4 #

- 2) Dynamic battery testing can be performed daily or weekly automatically with the appropriate command code programmed at Location 86. If the communicator to enabled, a battery status report will be sent on the following testing results:
 - a) The battery is LOW.
 - b) The battery resumes normal but it was LOW.NO report will be sent, if the battery is normal and it was normal at the last testing.
- 3) The battery's current status is always shown on the BATTERY LED indicator.
- 4) Except the LED light indication, the control console gives continuous 1 short beep/30 seconds after the system announced for battery low until the system retests the battery and considers that the battery has resumed normal again.
- 5) Dynamic battery testing is not accepted in AC power failure condition, or, when the system is in alarm.

BATTERY LOW INDICATIONS AND AUTO RESET

- 1) The battery low indication begins at 11.0V the battery under loaded condition at dynamic battery testing.
- 2) The battery low indication begins at the battery voltage drops to 11.0V for more than 2 minutes in AC power failure condition. A battery low report will be sent if the communicator is enabled.
- 3) The system will be reset to stop working when the battery voltage drops to 10V in AC power failure condition.

POWER-UP DELAY

The system can be programmed with or without power-up delay by keying-in the appropriate command code at location 85.

The **AC POWER** and the **BATTERY** lights are flashing alternatively; and the system gives no any function during the power-up delay period.

THE BACK-UP BATTERY

- 1) The back-up battery for the system should be a 12V, 6.5AH sealed lead-acid battery.
- 2) Replace battery every 3-5 years.
- 3) The standby time is 16 hours at 250mA.
- 4) The maximum battery charge current is 350mA in the system.
- 5) The battery is protected by a built-in 3A resettable fuse in the system.

GENERAL SPECIFICATION

- Power Source : 16.5V AC, 1.5Amp
- Backup Battery Requirement : 6.5AH, 12V, Rechargeable sealed lead acid
- Temperature Range : 0 Deg C to +65 Deg C
- Standby Current : 110mA
- Protection Zones : 8 Protection zones, end-of-line resistor supervised
- Control Station : Full function control station, 4 in parallel maximum
- G. Weight : 3.5 Kgs
: 4.3 Kgs (If with power transformer)
(One Master Unit & One Control Station packed in Carton)
- Dimensions Master Unit : 368(W) X 215(H) x 74(D) mm
 Control Station : 117(H) X 117(W) X 21(D) mm

OPENING THE CABINET FOR SERVICE

The Metal Cabinet of the HA-982 is protected by a built-in tamper switch which has been wired to zone 8 at the factory.

Zone 8 is a 24 hour protection zone on default settings. Opening of the Cabinet will trigger the tamper switch to make alarm.

If service is required, such as replacing a back-up battery, checking the connection wires, plugging in a extension microphone...etc., it is necessary to isolated the tamper switch before opening of the cabinet, and it can be accomplished by one of the following two ways:

1) Isolating of the tamper switch can be accomplished by isolating Zone 8.

Enter your [USER CODE], press the [ISOLATE] button, key in the zone number [8] and validate by [#].

[USER CODE] [ISOLATE] [8] [#]

- The tamper switch is isolated, two beeps are generated after the exit delay expired
- The zone 8 LED light is flashing **slow**

2) Disable the protection zones by setting system in PROGRAMMING MODE.

Enter the [MASTER CODE] and validate by pressing the [*] key twice.

[MASTER CODE] [*] [*]

- The system is in programming mode, two beeps are generated, the PROGRAM LED light is on.
- The protection zones including zone 8 are disabled while the system is in programming mode.

Now, you can open the Cabinet without making an alarm, Suggest to use a jumper wire (*metal wire*) shorting the tamper switch terminals in order to disable its function in all conditions for those testings and services required the cabinet opened for a period of time. After that, you are allowed to arm-disarm the system, or, to do anything in service without triggering of the tamper switch.

Don't forget to remove the jumper wire that you have put on the tamper switch after service. Before removing the jumper, please make sure that zone 8 is still in isolation or has been set in isolation again after the operational tests in service. Otherwise, the system will give alarm once the jumper wire is removed.