

Intelligent Parking Lock

CWZ2F-ML



Technical Parameters

Model: CWZ2F-ML	Intelligent Parking Lock
Working power (battery)	6V 7AH
Static Current	3.5MA
Working Current	3.5A
Power Voltage	DC6V
Work Time/Recharge	3 months
Up or Down Time	6 seconds
Descended Height	420mm
Down Height	75mm
Remote Controlled Distance	≤ 15m
Environment Temperature	-20° C ~ +55° C
Net Weight	8kg
Gross Weight	11kg
Dimensions	460 X 460 X 75mm

Structure Chart

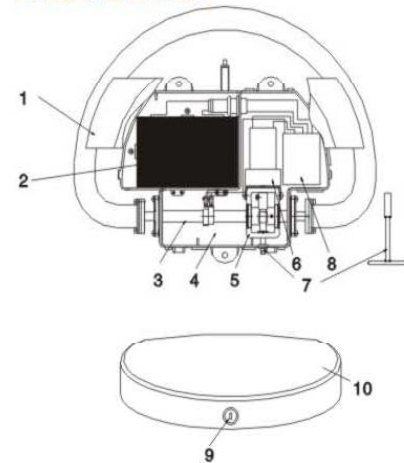

- | | |
|---------------------------|--------------------|
| 1.Rocker Assembly | 6.Electrical Motor |
| 2.Battery | 7.Manual Mechanism |
| 3.Drive Assembly | 8.Control Panel |
| 4.Box Body Assembly | 9.Locks |
| 5.Worm Gear Case Assembly | 10.Upper Cover |

Function and Features

- 1. The Intelligent remote control parking lock is an intelligent product specialized for car parking, which can effectively prevent the personal parking space from being occupied by other vehicles and bring actual conveniences of personal car parking. You can abandon the annoyances of manual parking lock and just enjoy the high quality life by high-tech control even without getting off your cars.
- 2. The Intelligent remote control parking lock applied the specially designed chip provided by Microchip Technology Inc. in America, the biggest single-chip designers and manufacture of the world, which brings more controllability, portability and high technical quality to the product.
- 3. Self-adapting mode is adopted in the remote controller, which has the capability of self-learning compared with the majority of remote controller in the market. "Self-learning" can be made again in case that the remote controller is out of order, without being return to the manufacturer for configuring.
- 4. With the high performance battery, the average service time for one charging can be as long as 3 months.
- 5. One-time die casting forming high temperature technology is employed on the molds, which effectively enhanced the overall intension and integrity of the product. The overall pressure resistance ability can be as high as 2 tons and the service life can be as long as 5 years. The product also with the characteristics of easy installation, nice appearance, firm structure and durability.
- 6. Advanced airtight design in this industry is adopted to achieve a truly effective waterproof, which enables the product can be put into operation at any indoor and outdoor occasions and under rainy or snowy weathers.
- 7. 0° rocker arm can effectively prevent the vehicles from entering the personal parking space and make the users at ease.
- 8. The function of power shortage indication is provided. When the voltage of the battery is not enough, the alarm will make intermittent alarming to remind user to recharge the storage battery in time.
- 9. Equipped with malfunction emergency unit. If the product is out of work as the battery is running out or other reasons, special designed emergency unit can be used to make manual lifting or falling or the rocker arm of the parking lock.

** Due to our continuous improvement, the content in this brochure may be different from time to time. The manufacturer reserves the right to alter any specification for improvement without prior notice.

